



E-Studio™ & E-box™ ***Balanced Flue***

With upgradable control valve

Instructions for Use, Installation and Servicing

For use in GB, IE (Great Britain and Eire)

This appliance has been certified for use in countries other than those stated. To install this appliance in these countries, it is essential to obtain the translated instructions and in some cases the appliance will require modification. Contact Gazco for further information.

IMPORTANT

Do not attempt to burn rubbish on this fire. This appliance must only be operated with the glass window secured firmly in position. The front casing of this appliance will become hot whilst in operation, it is therefore recommended that a suitable guard should be used for the protection of young children, the elderly or infirm.

Please read these instructions carefully before installation or use. Keep them in a safe place for future reference and when servicing the fire.

The commissioning sheet on page 3 MUST be completed by the Installer.

CONTENTS

Covering the following models:

8692BFCHUC 8692MCUC 8692PBUC
P8692BFCHUC P8692MCUC 8692PBUC

APPLIANCE COMMISSIONING CHECKLIST	3
USER INSTRUCTIONS	4
INSTALLATION INSTRUCTIONS	11
Technical Specifications	11
Site Requirements	14
Installation	16
Commissioning	23
SERVICING INSTRUCTIONS	24
Servicing Requirements	24
Fault Finding	24
How to replace parts	26
Basic spare parts list	31
Service Record	32

APPLIANCE COMMISSIONING CHECKLIST

IMPORTANT NOTICE

Explain the operation of the appliance to the end user, hand the completed instructions to them for safe keeping, as the information will be required when making any guaranteed claims.

FLUE CHECK	PASS	FAIL
1. Flue is correct for appliance		
2. Flue flow test	N/A	
3. Spillage test	N/A	
GAS CHECK		
1. Gas soundness & let by test		
2. Standing pressure test	mb	
3. Appliance working pressure (on High Setting) NB All other gas appliances must be operating on full	mb	
4. Gas rate	m ³ /h	
5. Does ventilation meet appliance requirements	N/A	
6. Have controls been upgraded (Upgradeable models only)	8455 Standard	YES NO
	8456 Programmable Thermostatic and Timer	YES NO

DEALER AND INSTALLER INFORMATION

Dealer **Installation Company**

Contact No...... **Engineer**
Date of Purchase..... **Contact No.**.....
Model No...... **Corgi Reg No.**.....
Serial No...... **Date of Installation**
Gas Type

This product is guaranteed for 2 years from the date of installation, as set out in the terms and conditions of sale between Gazco and your local Gazco dealer. **This guarantee will be invalid, to the extent permitted by law, if the above Appliance Commissioning Checklist is not fully completed by the installer and available for inspection by a Gazco engineer.** The guarantee will only be valid during the second year, to the extent permitted by law, if the annual service recommended in the Instructions for Use has been completed by a Corgi registered engineer, and a copy of the service visit report is available for inspection by a Gazco engineer.

USER INSTRUCTIONS

1. GENERAL

- 1.1 Installation and servicing must only be carried out by a competent person.
- 1.2 In all correspondence, please quote the appliance type and serial number, which can be found on the databadge adjacent to the control knob.
- 1.3 Ensure that curtains are not positioned above the fire, and that there is a 300mm minimum clearance between the sides of the fire and any curtains.
- 1.4 This product is guaranteed for 2 years from the date of installation, as set out in the terms and conditions of sale between Gazco and your local Gazco dealer. Please consult with your local Gazco dealer if you have any questions. In all correspondence always quote the Model Number and Serial Number.
- 1.5 Parts of this appliance become hot during normal use. It is therefore recommended that a suitable fire guard be used for protection of young children and the infirm.
- 1.6 If any cracks appear in the glass panel do not use the appliance until the panel has been replaced.

2. LIGHTING THE APPLIANCE

- 2.1 Locate the control valve on the appliance. There are two control knobs on the valve, the right hand knob controls the pilot ignition and the left hand knob controls the main burner.
- 2.2 If your appliance has already been upgraded to battery remote control, please refer to the instructions provided with the upgrade to operate the remote control. The following instructions will work for either situation.

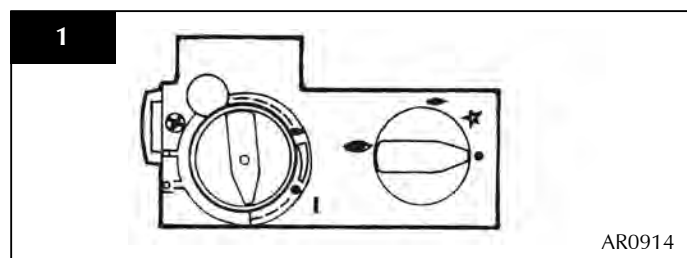

- Ensure that the left-hand control knob is pointing to off (●).
- Ensure that the right hand control knob is pointing to off (●).
- Press in the right hand control knob and rotate it anti-clockwise until a click is heard (keep pressing in) and the

knob is pointing to pilot (🔥). The pilot should now light. If the pilot has not lit, repeat the procedure until it does.

- Keep the control knob pressed for 10 seconds and then release it, the pilot should stay alight. If the pilot goes out, repeat the procedures until it does.
- 2.3 If the pilot will not light after repeated attempts, contact the retailer or installer from whom the appliance was purchased.
 - Turn the right-hand control to point to main burner (🔥). The fire can now be controlled using the left-hand control knob.
 - Turn the left hand control knob to point to low fire (🔥), the main burner will light on low. The burner can now be controlled between low and high settings. Turn the control knob anticlockwise to increase the flame height and clockwise to decrease the flame height.

3. TURNING THE APPLIANCE OFF

- 3.1 To turn the fire off, locate the control valve, turn the left-hand control knob until it points to off (●). The main burner will go out leaving the pilot burning.
- 3.2 To turn the pilot off, locate the control valve, turn the right hand control knob until it points to off (●), the pilot will go out.

4. UPGRADING YOUR FIRE

- 4.1 Your fire is fitted with a control valve that can easily be upgraded to battery powered remote control. This upgrade can be fitted by anyone capable of simple DIY jobs and requires no special training. This upgrade can be obtained through your local Gazco stockist.
- 4.2 **STANDARD REMOTE CONTROL** This remote control can control the fire after the pilot has been lit. It can turn the main burner on and regulate it from low through to high and back again. It can turn the main burner off leaving the pilot burning GAZCO PART NUMBER 8455.
- 4.3 **PROGRAMMABLE THERMOSTATIC AND TIMER REMOTE CONTROL.** This remote control can control the gas appliance after the pilot has been lit. In **MANUAL MODE** it can be used to turn the main burner on and manually regulate it from low through to high and back again. It can be used to turn the main burner off, leaving the pilot burning. In **AUTO MODE** it will automatically regulate the room temperature to a pre-set temperature. In

USER INSTRUCTIONS

TIMER MODE it will turn the fire on and off according to pre-set programme and automatically regulate the room temperature during the two periods. GAZCO PART NO. 8456.

CLEANING THE FIRE

ENSURE THE FIRE IS COLD BEFORE PROCEEDING

- 5.1 • Refer to the separate *Frame Instructions* to remove the frame from the fire.

5A. CLEANING THE E-STUDIO

- 5.2 • Remove the glass window by unscrewing the 8 screws in the glass window frame, Diagram 2

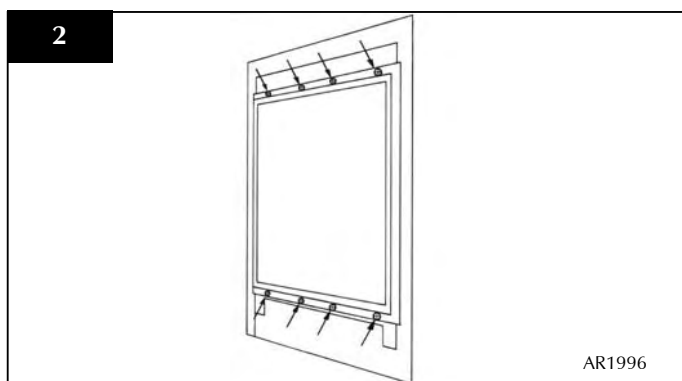

- 5.3 To clean the glass surface, Gazco recommends you use a ceramic glass product generally sold for cleaning ceramic hobs.
- Remove the granite chippings and place on a dry clean surface. Do not remove the enamel back panel
 - Use a damp cloth and mild non-abrasive cleaner on the enamel back panel
 - Clean the burner and tray assembly using a vacuum cleaner with a soft brush attachment
 - Ensure all debris is removed from the burner ports
 - Replace the granite chippings by referring to Section 6A for E-Studio.

5B. CLEANING THE E-BOX

- 5.4 • Remove the glass window by loosening the four screws in the lower retaining bracket
- Remove the four top screws and retaining bracket. The glass window can now be lifted clear. See diagram 3.

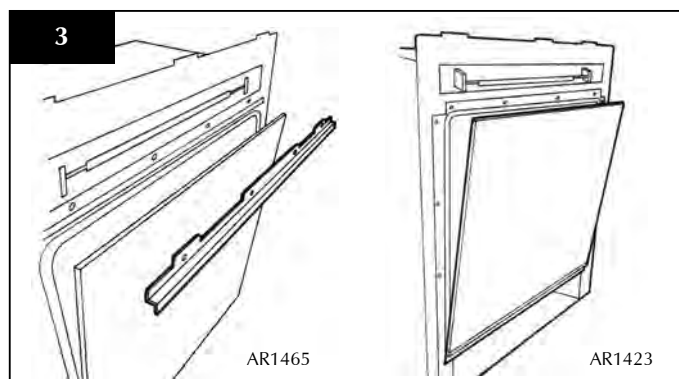

- 5.5 To clean the glass surface, Gazco recommends you use a ceramic glass product generally sold for cleaning ceramic hobs.
- Remove the ceramic coals or pebbles and fuel bed and place on a dry clean surface
 - Clean the burner and tray assembly using a vacuum cleaner with a soft brush attachment
 - Ensure all debris is removed from the ports
 - Replace the ceramics by referring to section 6B

ADVICE ON HANDLING AND DISPOSAL OF FIRE CERAMICS

The fuel effect and side panels in this appliance are made from Refractory Ceramic Fibre (RCF), a material which is commonly used for this application.

Protective clothing is not required when handling these articles, but we recommend you follow normal hygiene rules of not smoking, eating or drinking in the work area and always wash your hands before eating or drinking.

To ensure that the release of RCF fibres are kept to a minimum, during installation and servicing a HEPA filtered vacuum is recommended to remove any dust accumulated in and around the appliance before and after working on it. When servicing the appliance it is recommended that the replaced items are not broken up, but are sealed within heavy duty polythene bags and labelled as RCF waste.

RCF waste is classed as stable, non-reactive hazardous waste and may be disposed of at a licensed landfill site.

Excessive exposure to these materials may cause temporary irritation to eyes, skin and respiratory tract; wash hands thoroughly after handling the material.

USER INSTRUCTIONS

6A. ARRANGEMENT OF THE FUEL BED COMPONENTS - E STUDIO

ONLY USE THE CORRECT TYPE AND QUANTITY OF GRANITE CHIPPINGS. ALWAYS FOLLOW THE FUEL BED LAYOUT AS STATED IN THESE INSTRUCTIONS. NEVER CHANGE THE LAYOUT FROM THAT SHOWN HERE.

- 6.1
- Arrange the granite chippings in the areas highlighted in Diagram 4. Granite chippings should be evenly distributed.

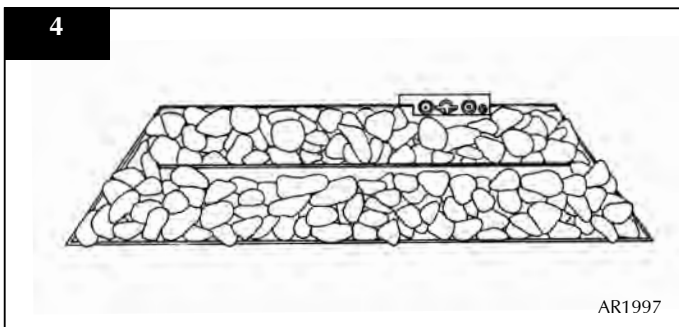

- Lean the granite chippings against the burner ledges to disguise the ledges, Diagram 5

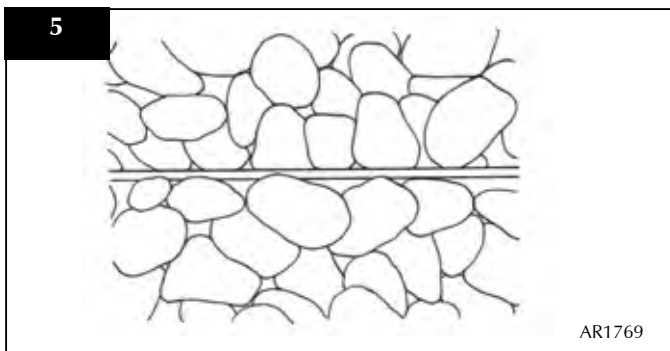

- Check that the port area. Arrow A, Diagram 6 is clear of granite chippings. This can be easily done by gently running a screwdriver or similar object along this area.

NOTE: IT IS IMPORTANT THE GRANITE CHIPPINGS DO NOT COVER THE PORT AREA IN BETWEEN THE BURNER LEDGES.

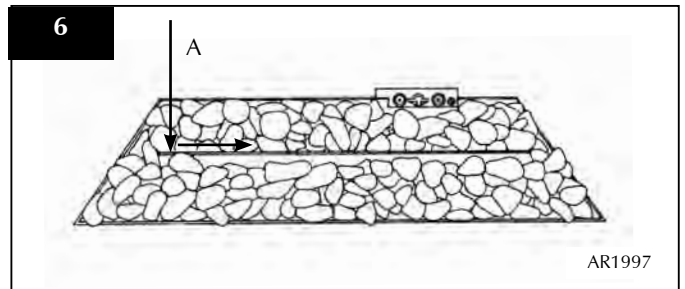

- Ensure that no chippings overhang or fill the pilot area, Arrow B, Diagram 7.

NOTE: CHIPPINGS SHOULD NOT BE PLACED DIRECTLY IN FRONT OF THE PILOT CROSS LIGHTING FLAME.

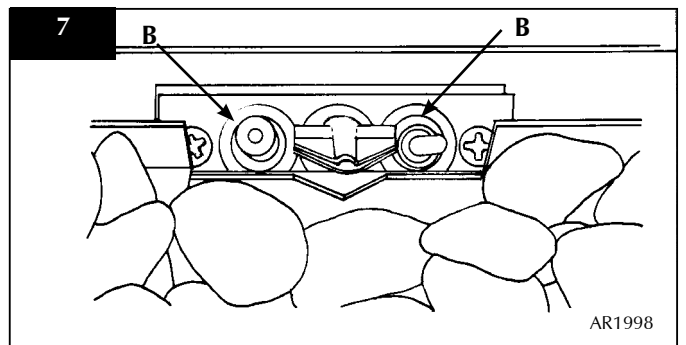

FITTING THE GLASS WINDOW - E-STUDIO

- 6.2
- Ensure that the fibre glass window seal on the box is intact
 - Replace the one-piece glass window frame, ensuring that all 8 fixings are tight, Diagram 8.

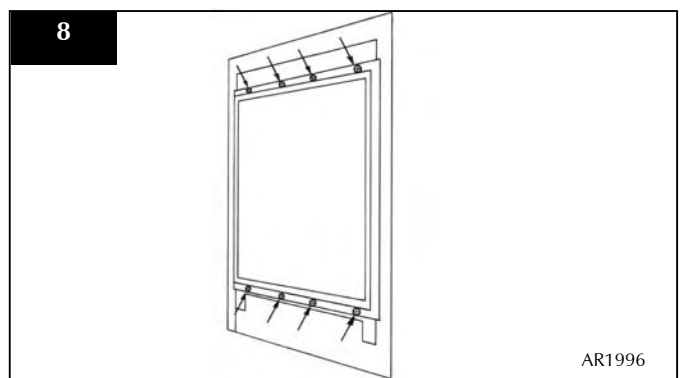

NEVER OPERATE THE FIRE WHEN THE GLASS PANEL IS REMOVED OR BROKEN

USER INSTRUCTIONS

- Refer to the separate *Frame Instructions* to replace the frame on the fire

6B. ARRANGEMENT OF THE FUEL BED COMPONENTS - E-BOX

NOTE: CERAMIC PARTS ARE FRAGILE. HANDLE WITH CARE

ONLY USE THE CORRECT TYPE AND QUANTITY OF CERAMIC COMPONENTS

- 6.3
- Place the rear panel against the rear of the box resting on the shelf
 - Slide one of the side panels into the box ensuring it touches the rear panel
 - Gently ease the front edge of the side panel behind the flange so it lies flat against the wall of the box
 - Repeat with the second side panel, Diagram 9

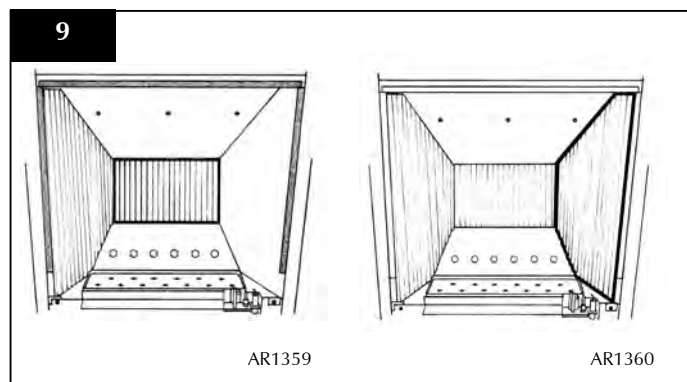

- Locate the top panel on top of the sides and rear by lifting it up and forward inside the box
- Slide it backwards and down behind the side panels to rest on the rear panel, Diagram 10

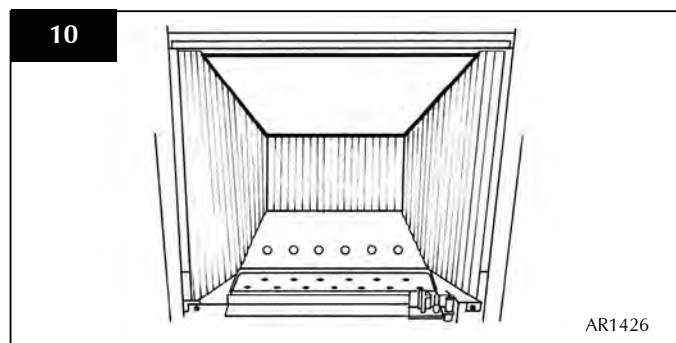

COAL LAYOUT

- 6.4
- Position the flame baffle centrally on the tray and ensure the stepped lower edge engages against the rear edge of the burner skin, Diagram 11

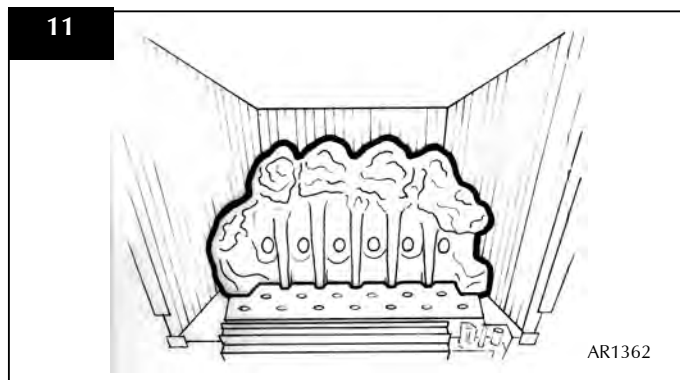

- Place the front coal centrally in the channel at the front of the tray. The relationship between the front coal and the flame baffle is shown, Diagram 12.

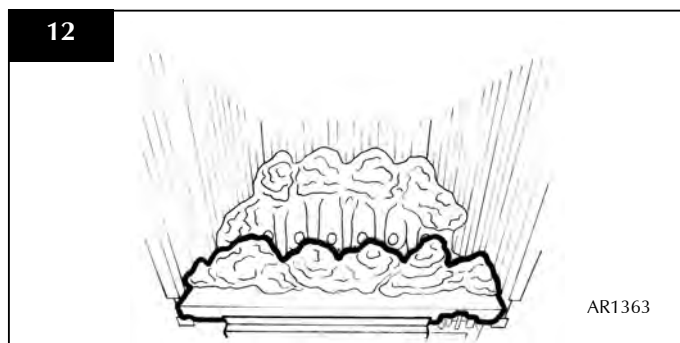

- 6.5
- There are three sizes of coal used. Small x3, medium x4 and large x1. For identification, Diagram 13.

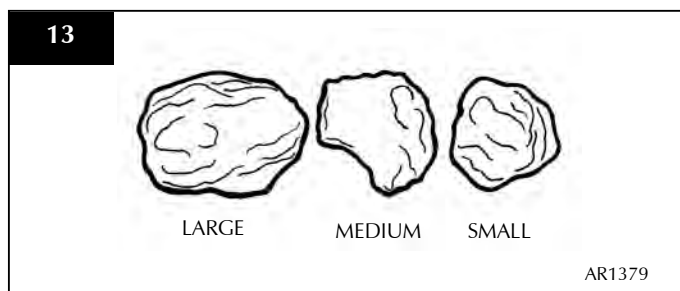

- Place the single large coal in the central dent of the front coal resting against the flame baffle, Diagram 14.

USER INSTRUCTIONS

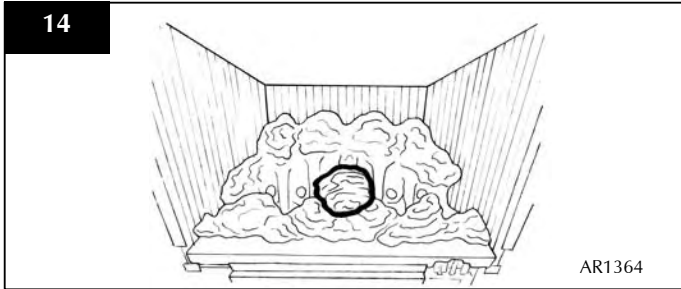

- Place 2 medium-size coals either side of the first large coal, in the recess between the flame baffle and the front coal, Diagram 15.

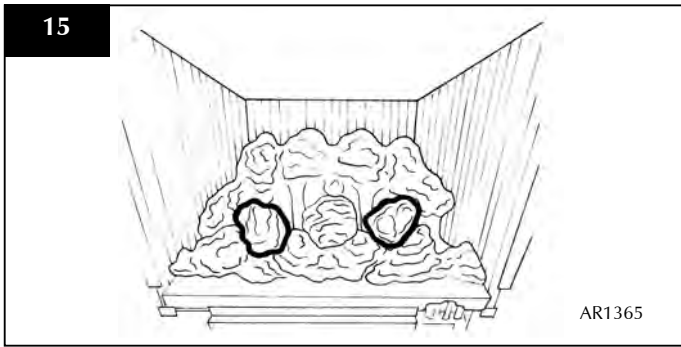

- Place another two medium size coals behind the first three coals and against the flame baffle, Diagram 16.

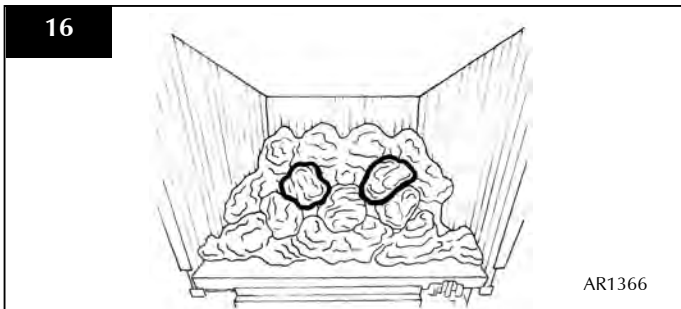

- Place a small coal directly behind the first large coal, and in between the centre of the last two medium coals resting on the flame baffle, Diagram 17.

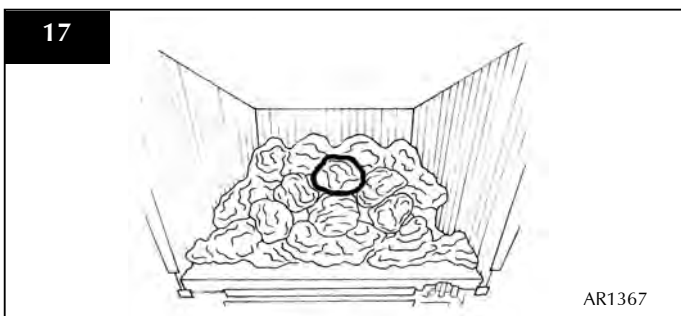

- Place the last two small coals to the left and right-hand side of the bed in the two spaces, Diagram 18.

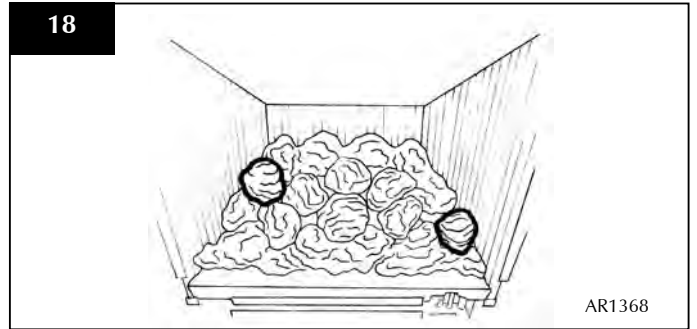

PEBBLE LAYOUT

- Position the pebble flame baffle centrally on the tray and ensure the stepped lower edge engages against the rear edge of the burner skin, Diagram 19.

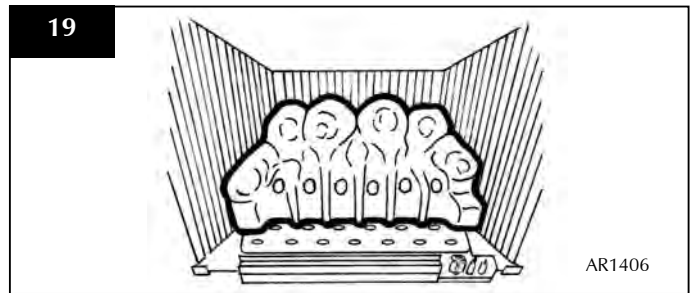

- Place the front pebble piece centrally in the channel at the front of the tray. See Diagram 20.

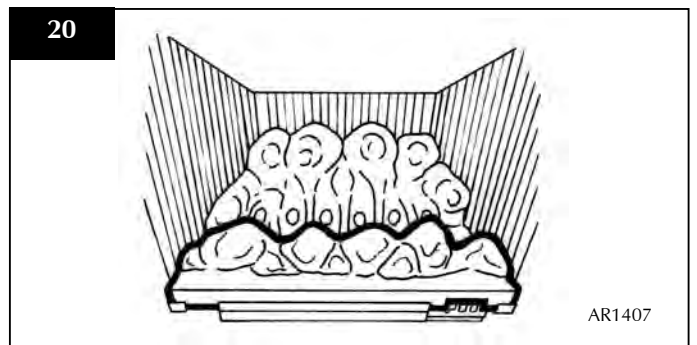

- 6.6 There are 10 loose pebbles in the set supplied. Each pebble is individually marked. The quantity of each type is shown below.

A1 x 3	A4 x 1
A2 x 1	A5 x 1
A3 x 3	A6 x 1

- Place the four pebbles as identified resting between the front ceramic and the flame baffle as shown in diagram 21.

USER INSTRUCTIONS

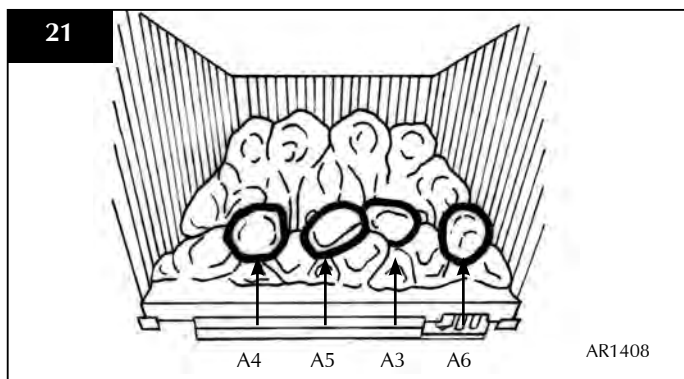

- Place the next four pebbles as shown resting between the flame baffle and the first row of pebbles, Diagram 22.

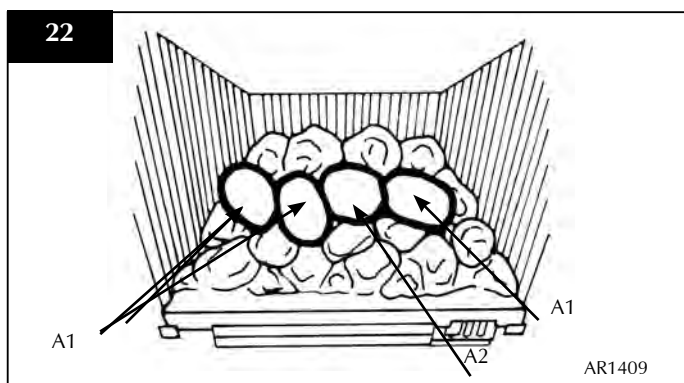

- Place the remaining two A3 pebbles as shown in Diagram 23.

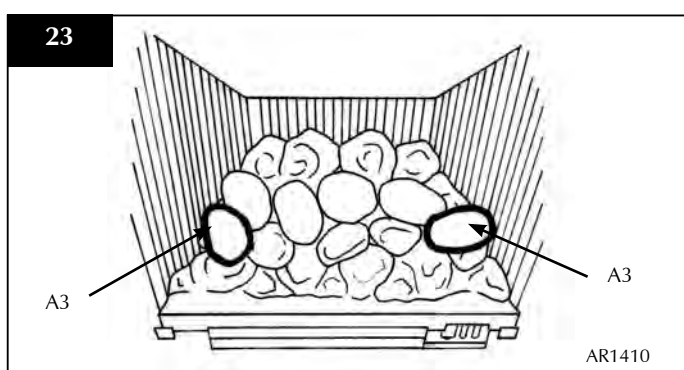

- 6.7 The coals/pebbles should evenly cover the whole bed with the gaps between them kept equal. This will maximise the performance of the product.
- 6.8 **ENSURE THAT THE COALS/PEBBLES ARE POSITIONED AS ABOVE. ONLY USE THE CORRECT AMOUNT OF COALS/PEBBLES AS SPECIFIED IN THE DIAGRAMS.**

FITTING THE GLASS WINDOW - E-BOX

- 6.9
- Ensure that the fibre glass window seal on the box is intact, then lower the glass window into the lower retaining bracket.
 - Hold the window and position the upper retaining bracket
 - Secure using the 4 screws.
 - Tighten the bottom and top screws to retain the window, Diagram 24.

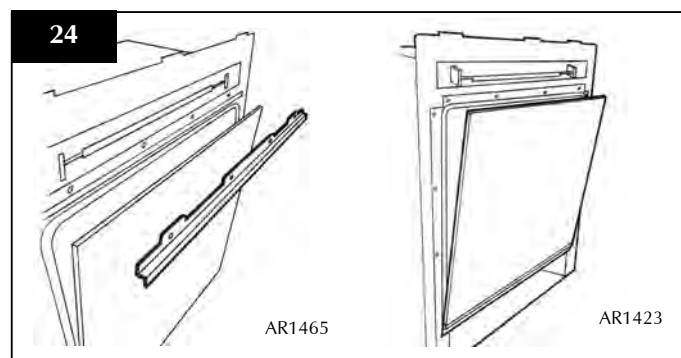

- Refer to the separate *Frame Instructions* to replace the frame on the fire.

NEVER OPERATE THE APPLIANCE WHEN THE GLASS PANEL IS REMOVED OR BROKEN.

7. FLAME FAILURE DEVICE

- 7.1 This is a safety feature incorporated on this appliance which automatically switches off the gas supply if the pilot goes out and fails to heat the thermocouple.

8. RUNNING IN

- 8.1 The surface coating on the coals used in your GAZCO fire will "burn off" during the first few hours of use producing a harmless and temporary odour. This will disappear after a short period of use. If the odour persists, ask your installer for advice.

9. SERVICING

- 9.1 The fire must be serviced every 12 months by a qualified Gas Engineer. In all correspondence always quote the Model number and the Serial number which may be found on the databadge.

USER INSTRUCTIONS

10. VENTILATION

10.1 This appliance requires no additional ventilation.

11. INSTALLATION DETAILS

11.1 To assist in any future correspondence, your installer should have completed the commissioning sheet at the front of this book, this records the essential installation details of the appliance. In all correspondence always quote the Model number and Serial number.

12. HOT SURFACES

12.1 Parts of this appliance become hot during normal use. It is therefore recommended that a suitable fire guard be used for protection of young children and the infirm. Indeed, all parts of the appliance should be treated as a 'working surface' except for the control access panel.

INSTALLATION INSTRUCTIONS

TECHNICAL SPECIFICATION

Covering the following E-STUDIO models:

8692BFCHUC

P8692BFCHUC

GAS CATEGORY	I ₂ H	I ₃ P
	Natural	Propane
Gas Type	G20	G31
Working Pressure	20mbar	37mbar
Gross Input kW	HIGH	4.3kW
	LOW	2.5kW
Gas Rate m ³ /hr	0.401	0.138
Efficiency Class	2	2
NO _x Class	4	4
Injector Size	158	170R
Aeration Size	8mm x 15mm	23mm x 15mm
		23mm x 15mm
Flue Outlet Size	100mmø / 152mmø	
Gas Inlet	8mm	

APPLICABLE FRONTS	
FRONT	PART NUMBER
Designio	8272BFMA + 8272BFIR + 8272BFGP
Progress	8253BFMA + 8253BFIR
Dimension	8680MB
Steel	8695GP + 8695IR
Evolution	8258BS + 8258MB
Arts	8282MB + 8282HP + 8282P + 8282PBR
Steel	8695GP + 8695IR
Futura	8687BK
Fusion	8699GP + 8699IR
Winchester	8697MB + 8697P

APPLICABLE FRAME & FRONT COMBINATIONS		
FINISH	ARTS FRAME	ARTS FRONT
Black	8283BFMB	8282MB
Brass	8283BFPBR	8282PBR
Brushed Steel	8283BFBS	
Polished Steel	8283BFP	
Highlight Polished		8282HP
Chrome		8282P

INSTALLATION INSTRUCTIONS

TECHNICAL SPECIFICATION

Covering the following E-BOX models:

8692 MCUC 8692PBUC
P8692 MCUC P8692PBUC

GAS CATEGORY	I ₂ H	I ₃ P
	Natural	Propane
Gas Type	G20	G31
Working Pressure	20mbar	37mbar
Gross Input kW	HIGH 4.1kW	4.1kW
	LOW 2.3kW	2.5kW
Gas Rate m ³ /hr	0.390	0.154
Efficiency Class	1	1
NO _x Class	3	3
Injector Size	260	104
Aeration Size	12mm x 15mm	6mm x 15mm
		23mm x 15mm
Flue Outlet Size	100mmø / 152mmø	
Gas Inlet	8mm	

APPLICABLE FRONTS			
FRONT	PART NUMBER	FRONT	PART NUMBER
Designio	8272MA + 8272GP + 8272IR	Stockton	8696
Evolution	8258BS + 8258MB + 8258BS	Yeoman	YM98906
Infinity	8256BS	Holyrood	8693MB + 8693PBB + 8693HP
Progress	8253MA + 8253IR	Spanish	8694MB + 8694PBB + 8694HP
Richmond	8679	Futura	8687BK
Dimension	8680MB	Fusion	8699GP + 8699IR
Arts	8282MB + 8282HP + 8282P + 8282PBR	Winchester	8697MB + 8697P

APPLICABLE FRAME & FRONT COMBINATIONS				
FINISH	**ARTS FRAME	ARTS FRONT	HOLYROOD FRONT	SPANISH FRONT
Black	8283MB	8282MB	8693MB	8694MB
Brass	8283PBR	8282PBR		
Black/Brass			8693PBB	8694PBB
Brushed Steel	8283BS			
Polished Steel	8283P			
Highlight Polished		8282HP	8693HP	8694HP
Chrome		8282P		

** The Arts Frame must be used in conjunction with either the Arts, Holyrood or Spanish Front.

INSTALLATION INSTRUCTIONS

TECHNICAL SPECIFICATION

OVERALL EXTERNAL DIMENSIONS FOR BOTH E-STUDIO AND E-BOX

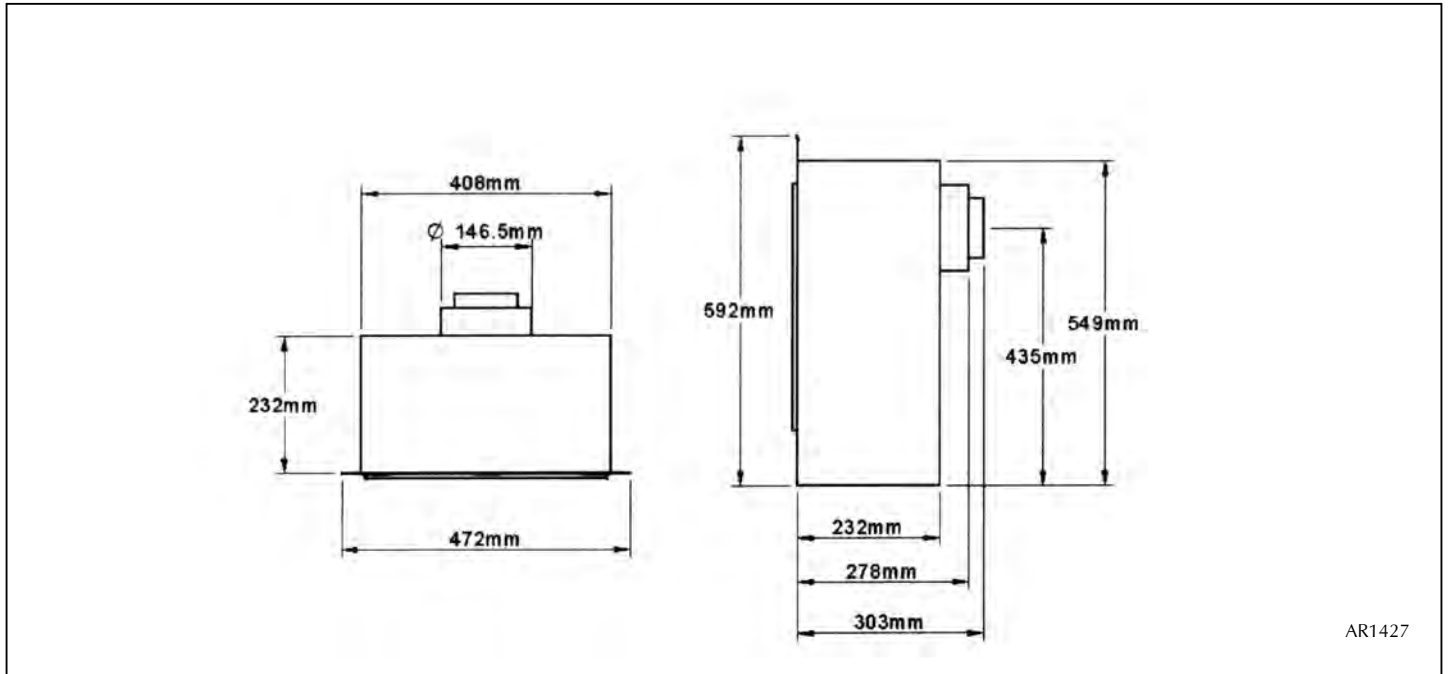

MINIMUM AND MAXIMUM FLUE SIZE

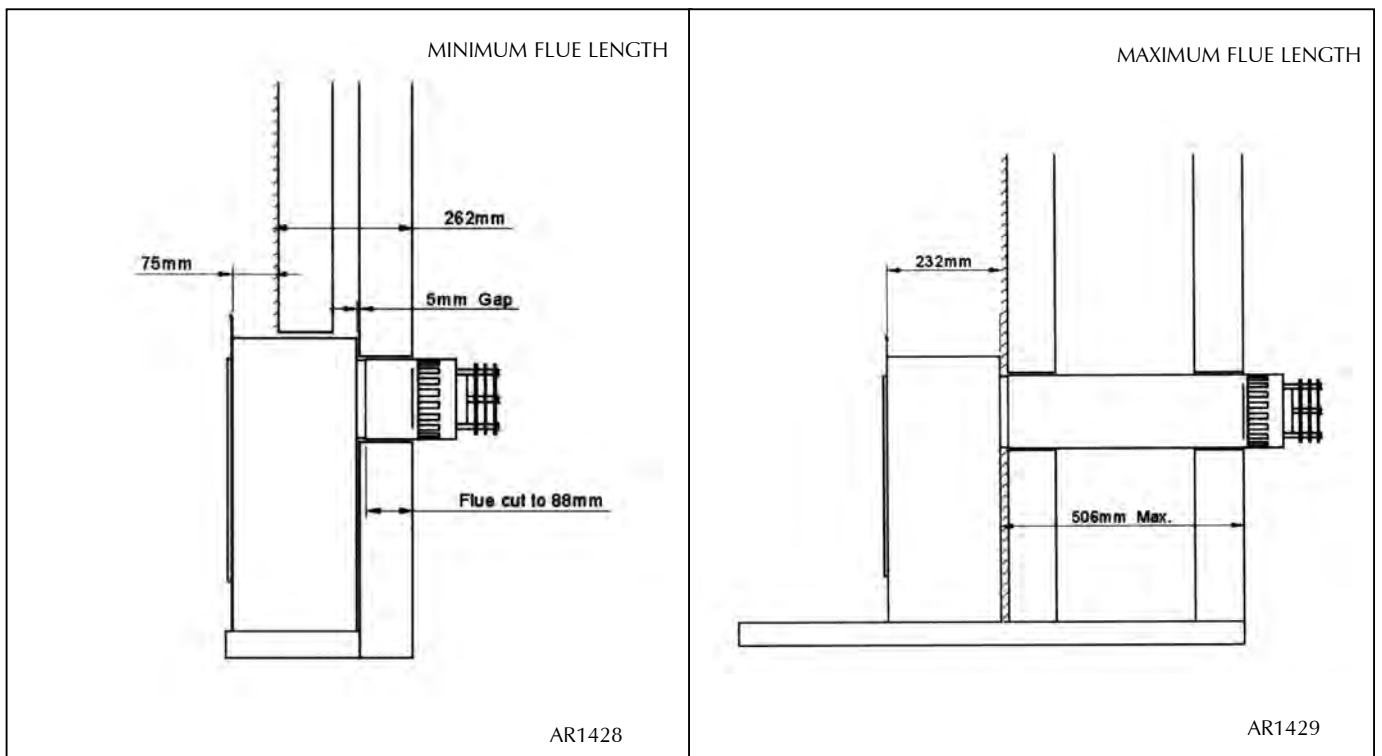

INSTALLATION INSTRUCTIONS

SITE REQUIREMENTS

1. FLUE AND CHIMNEY REQUIREMENTS

NOTE: This appliance can only be installed in conjunction with the flue supplied.

- 1.1 The flue must be sited in accordance with BS5440: Part 1 (latest edition), Diagram 1.
- 1.2 Any terminal which is less than 2 metres above any access (level ground, balcony or above a flat roof to which people have access) is to be fitted with a guard.
- 1.3 The flue must be securely fixed and fire precautions followed in accordance with local and national codes of practice.

- 1.4 The horizontal terminal can be reduced in length, Diagram 2.

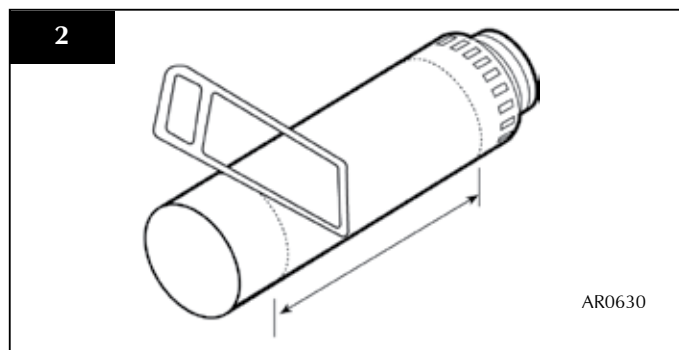

1

UK Dimensions

Dimension	Terminal Position	Minimum Distance (mm)
A*	Directly below an opening, air brick, opening windows etc	300 mm
B*	Above an opening, air brick, opening windows etc.	300 mm
C*	Horizontal to an opening, air brick, opening windows etc.	300 mm
D	Below gutters, soil pipes or drain pipes	300 mm
E	Below eaves	300 mm
F	Below balconies or car port roof	600 mm
G	From a vertical drain pipe or soil pipe	300 mm
H	From an internal or external corner	600 mm
I	Above ground, roof or balcony level	300 mm
J	From a surface facing the terminal (or boundary)	600 mm
K	From a terminal facing the terminal	600 mm
L	From an opening in the car port (e.g. door, window) into dwelling	1200 mm
M	Vertically from a terminal on the same wall	1500 mm
N	Horizontally from a terminal on the same wall	300 mm
O	From the wall in which the terminal is mounted	N/A
P	From a vertical structure on the roof	N/A
Q	Above intersection with roof	N/A

* In addition, the terminal should not be nearer than 300mm to an opening in the building fabric formed for the purpose of accommodating a built-in element such as a window frame.

H The reference to external corners does not apply to building protrusions not exceeding 450mm, such as disused chimneys on external walls.

INSTALLATION INSTRUCTIONS

SITE REQUIREMENTS

TIMBER FRAMED BUILDINGS

- 1.5 It will be necessary to provide additional clearance when the flue passes through a wall containing any combustible materials so as to prevent a fire hazard.
- 1.6 The hole through which the flue will pass, must have a steel sleeve which is positioned so that an air gap of at least 25mm is maintained between the outer surface of the flue, and any part of the sleeve.
- 1.7 For further guidance on the installation of gas appliances in timber framed buildings, contact your local buildings control authority.

2. GAS SUPPLY

- 2.1 Before installation, ensure that the local distribution conditions (identification of the gas type and pressure) and the adjustment of the appliance are compatible.
- 2.2 Ensure that the gas supply is capable of delivering the required amount of gas, and is in accordance with the rules in force.
- 2.3 Factory-sheathed/wrapped soft copper tubing with small ridges which allow pipe movement are considered to be a suitable alternative to a pipe sleeve, when recessing the unit into a cavity wall the gas supply is best fed through the wall from the outside. Soft soldered joints can only be used outside the appliance.
- 2.4 This appliance is supplied complete with a factory fitted isolation device incorporated into the inlet connection. No further isolation device is therefore required.

3. VENTILATION

- 3.1 This appliance requires no additional ventilation.

4. APPLIANCE LOCATION

NOTE: It is recommended you construct the back panel of the fireplace from natural materials cut into three or more sections to prevent cracking. Resin-based materials may not be suitable. This appliance is an effective heat producer and attention must be paid to the construction and finish of the fireplace.

- 4.1 This appliance must stand on a non combustible hearth that is at least 12mm thick. If the fire is greater than 50mm above the floor, then no hearth is required, although due consideration should be given to how the heat may affect the floor material.

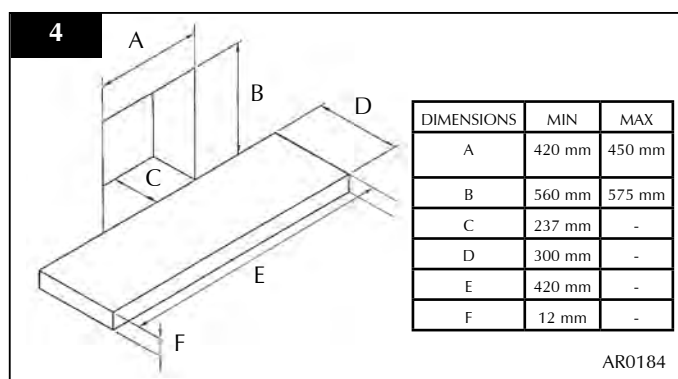

- 4.2 The minimum opening dimensions are shown, Diagram 4.
- 4.3 This appliance can only be installed on an outside wall with suitable clearances for the flue terminal and guard (if required).
- 4.4 This appliance is not suitable for installation into a combustible wall. All combustible material must be removed from the area shown, Diagram 5.

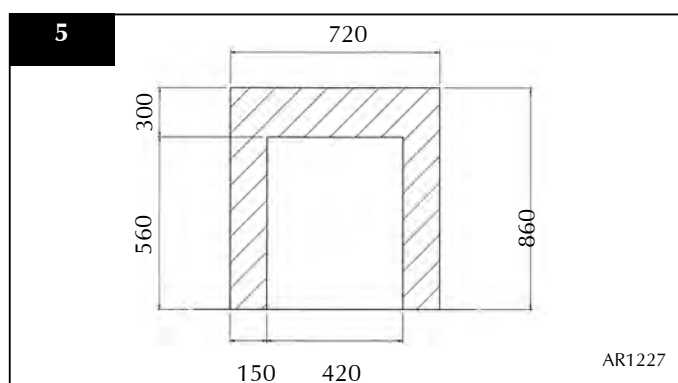

- 4.5 The maximum depth of combustible shelf is 150mm at a minimum height of 300mm above the fireplace opening.

INSTALLATION INSTRUCTIONS

INSTALLATION

1. UNPACKING

- 1.1
- Remove the appliance from its packaging, and check that it is complete and undamaged
 - Put the loose ceramic parts to one side so that they are not damaged during installation.

2. CONTROL UPGRADE

- 2.1 Your fire is fitted with a control valve that can be easily upgraded to battery powered remote control. This upgrade can be fitted by anyone capable of simple DIY jobs and requires no special training. This upgrade can be obtained through your local Gazco stockist.
- 2.2 **STANDARD REMOTE CONTROL** This remote control can control the fire after the pilot has been lit. It can turn the main burner on and regulate it from low through to high and back again. It can turn the main burner off leaving the pilot burning. GAZCO PART NUMBER 8455.
- 2.3 **PROGRAMMABLE THERMOSTATIC AND TIMER REMOTE CONTROL.** This remote control can control the gas appliance after the pilot has been lit. In **MANUAL MODE** it can be used to turn the main burner on and manually regulate it from low through to high and back again. It can be used to turn the main burner off, leaving the pilot burning. In **AUTO MODE** it will automatically regulate the room temperature to a pre-set temperature. In **TIMER MODE** it will turn the fire on and off according to pre-set programme and automatically regulate the room temperature during the two periods. GAZCO PART NO. 8456.

3. SAFETY PRECAUTIONS

- 3.1 This appliance must be installed in accordance with the rules in force, and used only in a sufficiently ventilated space. Please read all instructions before installation and use of this appliance.
- 3.2 These instructions must be left intact with the user.
- 3.3 Do not attempt to burn rubbish on this appliance.
- 3.4 In your own interest, and those of safety, this appliance must be installed by a competent person in accordance with local and national codes of practice. Failure to install the appliance correctly could lead to prosecution.
- 3.5 Keep all plastic bags away from young children.

4. INSTALLATION OF THE GAS SUPPLY

E-STUDIO BF	
NAT GAS @ 20MB	PROPANE @ 37mb
8692BFCHUC	P8692BFCHUC

E-BOX BF	
NAT GAS @ 20MB	PROPANE @ 37mb
8692MCUC	P8692MCUC
8692PBUC	P8692PBUC

TO CHANGE FROM ONE GAS TYPE TO ANOTHER A COMPLETE ENGINE ASSEMBLY WILL BE REQUIRED. SEE SECTION 12 REPLACING PARTS.

- 4.1 Before installation, ensure that the local distribution conditions (identification of the type of gas and pressure) and the adjustment of the appliance are compatible. See table above.
- 4.2 The position of the gas inlet pipe is shown, Diagram 3.

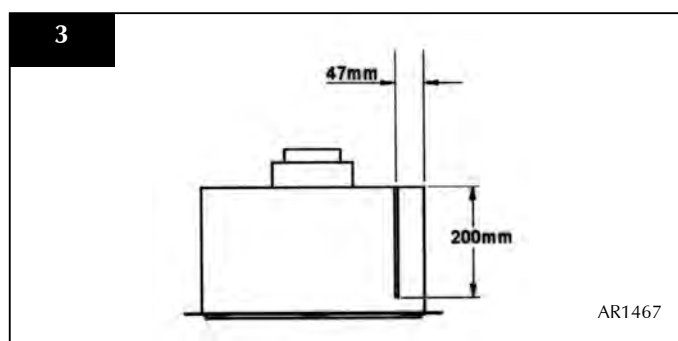

- 4.3 All supply pipes must be purged of any debris that may have entered, prior to connection to the appliance.
- 4.4 The gas supply enters through the silicone panel located on the rear of the outer box. This will need to be slit with a sharp knife prior to passing the supply pipe through.

5. PREPARING THE APPLIANCE

- 5.1 Remove the backing from the self-adhesive silicone sealing strip and apply to the rear flange of the firebox ensuring that the strip is positioned as close to the outer edge as is practically possible, Diagram 1, arrow A.

INSTALLATION INSTRUCTIONS

INSTALLATION

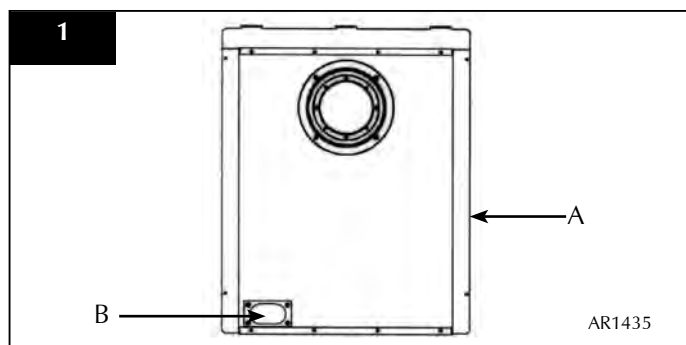

5.2 Gas pipe entry must come through the rear right-hand side of the box. The rubber seal must be cut using a sharp knife to allow the isolating elbow to pass through it.

- Ensure the rubber is not damaged when doing this, Diagram 1, arrow B.

A means of isolation is provided with the appliance. This must be fitted to the supply pipe prior to installing the firebox.

The appliance can either be recessed into an inner leaf of the wall. A 75mm rebate surround must be used with this method. Or it can be installed in front of the wall in conjunction with a fire surround constructed of a studwork frame, Diagram 2 for options.

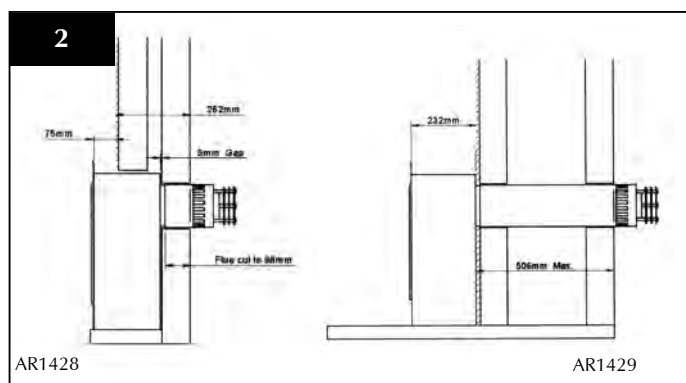

6. NON RECESSED INSTALLATION

6.1 • Mark the position of the flue on the inner wall by measuring from the top of the finished hearth level, Diagram 3.

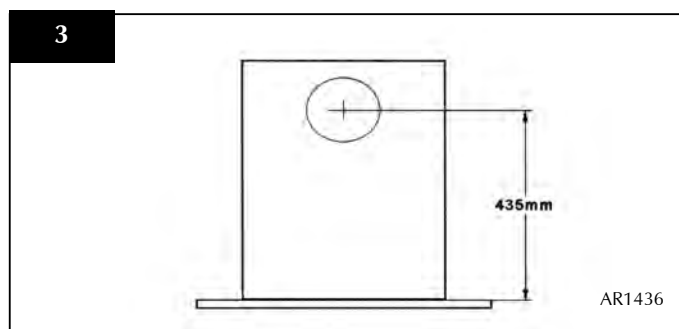

6.2 A 152mm (6") diameter hole is required to install the flue. This can be achieved by either:

- Core drill
- Hammer and chisel.

It is advisable to drill small holes around the circumference when using method b. Make good both ends of the hole.

6.3 It will now be necessary to construct a studwork frame to house the appliance. The minimum depth of the aperture must be 237mm. This includes an air gap of 5mm behind the appliance. The sides must be lined with non-combustible material for the full depth of the aperture.

6.4 Combustible parts of the studwork frame must not be any closer than the minimum dimensions shown in Diagram 4. These dimensions need to be maintained even if the frame work is protected by non combustible material.

6.5 Do not pack the void around or above the appliance with insulation material such as mineral wool.

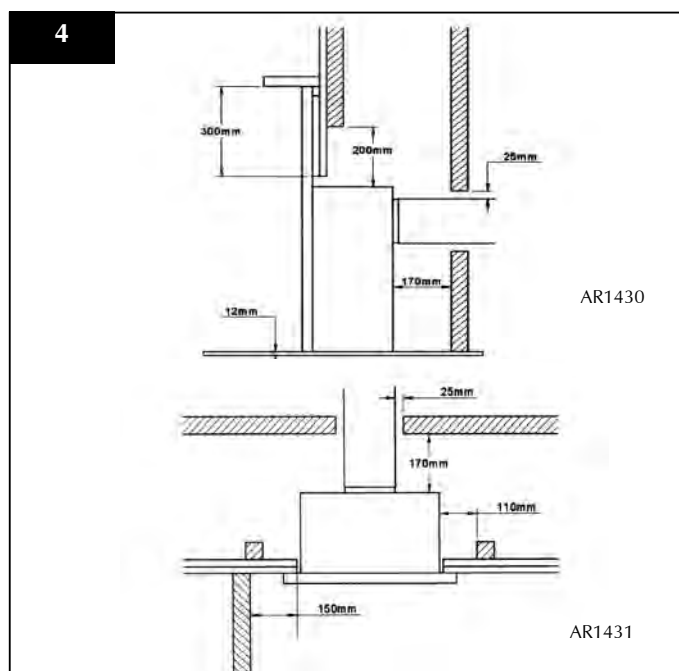

INSTALLATION INSTRUCTIONS

INSTALLATION

- 6.6 The void into which the appliance is fitted must be ventilated to prevent a build up of heat. If the void is sealed then it will be necessary to fit vents at both low and high levels of approximately 50cm². These vents should take cold air from the room and return warm air back into the room.

This method of installation requires structural alteration to the intended location. A suitable supporting lintel must be installed to maintain the structural integrity of the surrounding blockwork.

7. RECESSED INSTALLATION

- 7.1 Mark the position of the lintel so that it sits centrally over the intended installation. Remove the blockwork and install the lintel using mortar to ensure a strong bond with the surrounding wall, Diagram 5.

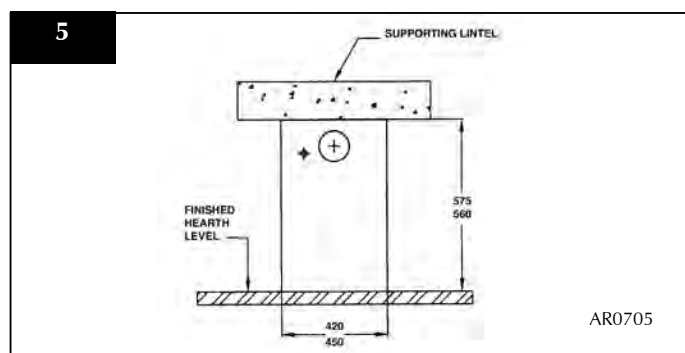

- 7.2 With the lintel in position mark the width of the aperture and remove the blockwork. If there is loose cavity insulation this must be retained. This can be achieved by using Rockwool or similar, Diagram 5.
- 7.3 Mark the position of the flue on the wall by measuring from the top of the finished hearth level, Diagram 6.

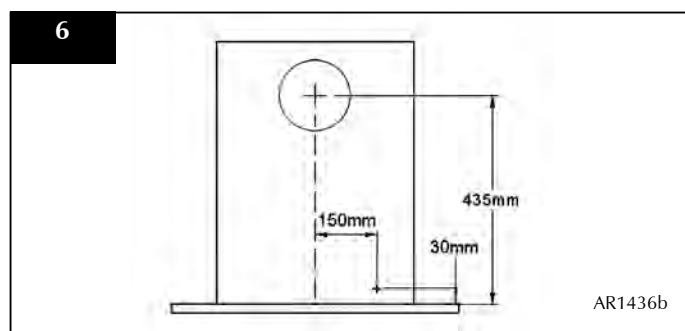

- 7.4 A 152mm (6") diameter hole is required to install the flue. This can be achieved by either:
- Core drill
 - Hammer and chisel
- It is advisable to drill small holes around the circumference when using method b. Make good both ends of the hole.

8. INSTALLATION OF THE APPLIANCE

- 8.1 The flue can be cut to length, measure the thickness of the wall the flue is passing through, then deduct 12mm. This is the length required when measuring from the line on the flue label. This must be level with the outside wall face when fitted, Diagram 7.

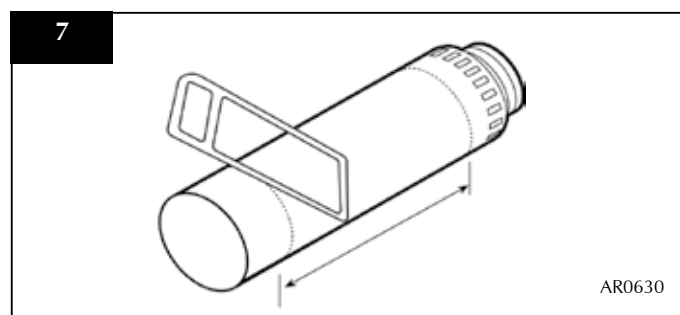

- 8.2 There is a cardboard fitment in the terminal. This is to support the flue whilst it is cut to length. **REMOVE THE REMAINDER OF THE CARDBOARD AFTER CUTTING TO SIZE**
- Remove the compression elbow from the appliance and connect it to the gas supply pipe, taking note of its orientation
 - Attach the flue to the appliance and seal using the aluminium tape provided
- 8.3 As the appliance is positioned into the opening of the enclosure, pass the flue pipe through the hole in the wall. It will be necessary to pass the supply pipe with the elbow through the silicone panel on the right hand side of the box.
- Secure the appliance in place using screws and rawl plugs provided
 - PURGE THE SUPPLY PIPE.** This is essential to expel any debris that may block the gas controls. Connect the elbow to the appliance inlet pipe.
- 8.4
- Connect a suitable pressure gauge to the test point located on the inlet elbow and turn the gas on
 - Light the appliance and check for leaks
 - Turn the appliance to maximum and check that the supply pressure is as stated on the databadge
 - Turn the gas supply off and replace the test point screw
 - Turn the gas on and check the test point for leaks

INSTALLATION INSTRUCTIONS

INSTALLATION

9A. ARRANGEMENT OF THE FUEL BED COMPONENTS - E STUDIO

ONLY USE THE CORRECT TYPE AND QUANTITY OF GRANITE CHIPPINGS. ALWAYS FOLLOW THE FUEL BED LAYOUT AS STATED IN THESE INSTRUCTIONS. NEVER CHANGE THE LAYOUT FROM THAT SHOWN HERE.

- 9.1
- Arrange the granite chippings in the areas highlighted in Diagram 8. Granite chippings should be evenly distributed.

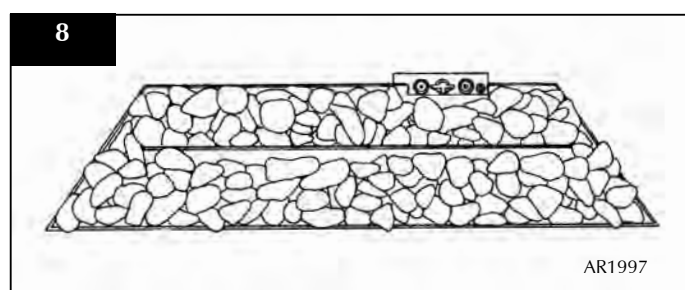

- Lean the granite chippings against the burner ledges to disguise the ledges, Diagram 9

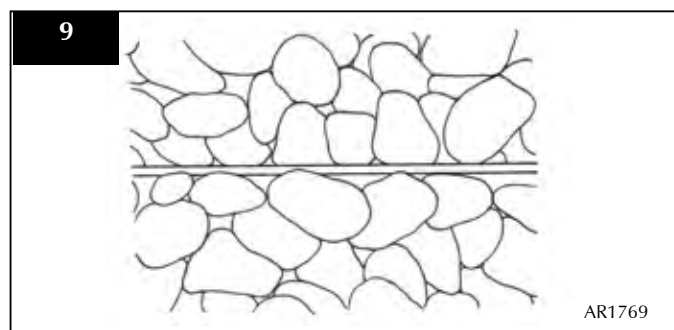

- Check that the port area. Arrow A, , Diagram 10 is clear of granite chippings. This can be easily done by gently running a screwdriver or similar object along this area.

NOTE: IT IS IMPORTANT THE GRANITE CHIPPINGS DO NOT COVER THE PORT AREA IN BETWEEN THE BURNER LEDGES.

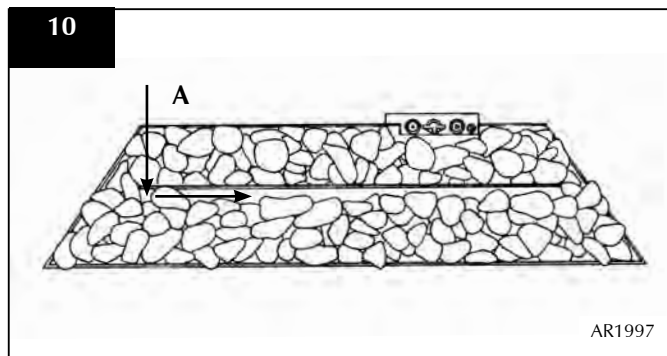

- Ensure that no chippings over-hang or fill the pilot area, Arrow B, Diagram 11.

NOTE: CHIPPINGS SHOULD NOT BE PLACED DIRECTLY IN FRONT OF THE PILOT CROSS LIGHTING FLAME.

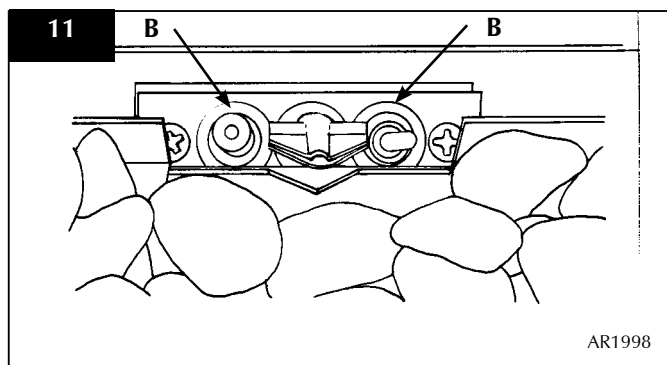

FITTING THE GLASS WINDOW - E-STUDIO

- Ensure that the fibre glass window seal on the box is intact.
- Replace the one-piece glass window frame ensuring that all 8 fixings are tight, Diagram 12.

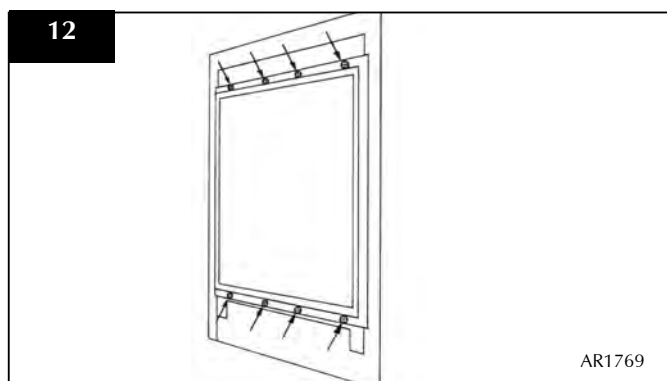

NEVER OPERATE THE FIRE WHEN THE GLASS PANEL IS REMOVED OR BROKEN

- Refer to the separate *Frame Instructions* to replace the frame on the fire

INSTALLATION INSTRUCTIONS

INSTALLATION

9B. ARRANGEMENT OF THE FUEL BED COMPONENTS - E-BOX

NOTE: CERAMIC PARTS ARE FRAGILE. HANDLE WITH CARE

ONLY USE THE CORRECT TYPE AND QUANTITY OF CERAMIC COMPONENTS

- 9.2
- Place the rear panel against the rear of the box resting on the shelf.
 - Slide one of the side panels into the box ensuring it touches the rear panel.
 - Gently ease the front edge of the side panel behind the flange so it lies flat against the wall of the box.
 - Repeat with the second side panel, Diagram 13

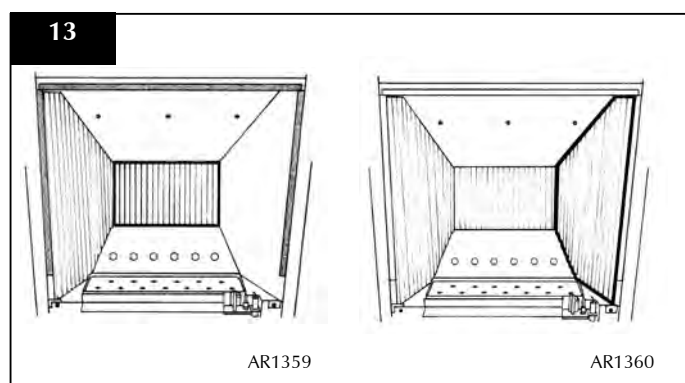

- Locate the top panel on top of the sides and rear by lifting it up and forward inside the box.
- Slide it backwards and down behind the side panels to rest on the rear panel, Diagram 14.

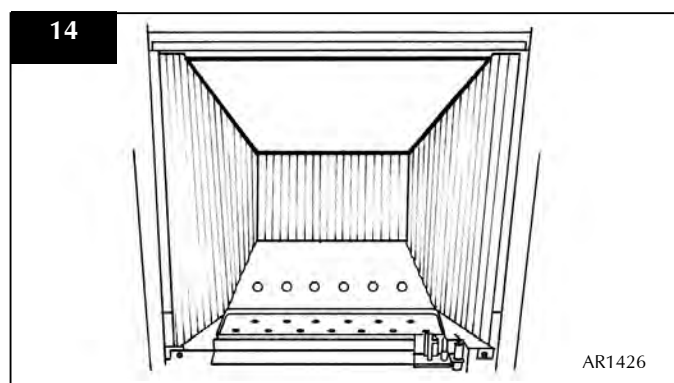

COAL LAYOUT

- 9.3
- Position the flame baffle centrally on the tray and ensure the stepped lower edge engages against the rear edge of the burner skin, Diagram 15

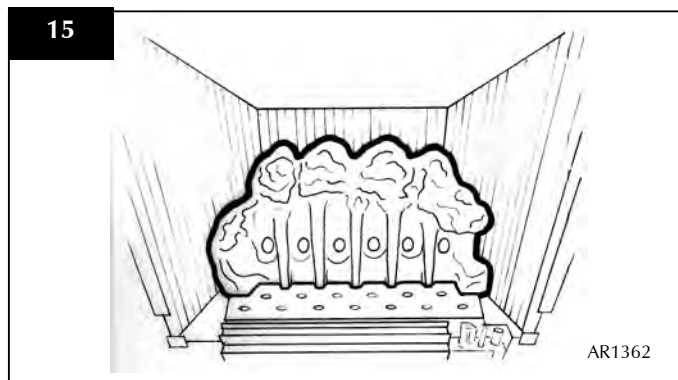

- Place the front coal centrally in the channel at the front of the tray. The relationship between the front coal and the flame baffle is shown, Diagram 16.

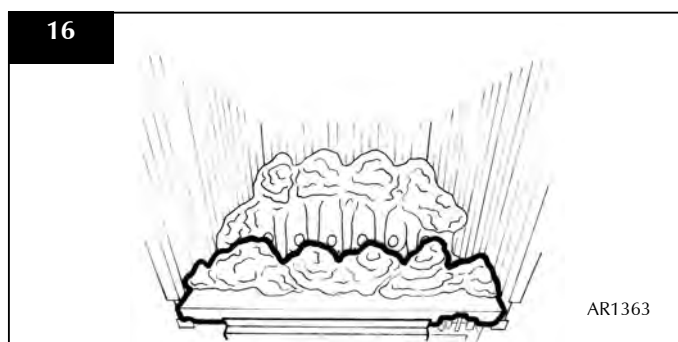

- 6.5
- There are three sizes of coal used. Small x3, medium x4 and large x1. For identification, Diagram 17.

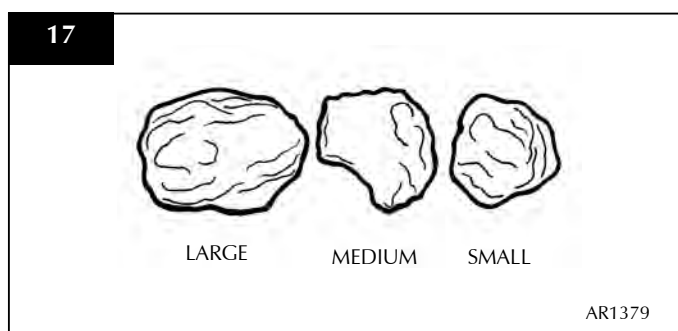

- Place the single large coal in the central dent of the front coal resting against the flame baffle, Diagram 18.

INSTALLATION INSTRUCTIONS

INSTALLATION

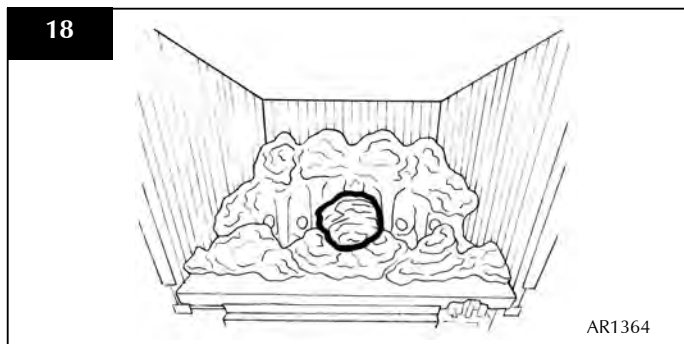

- Place 2 medium size coals either side of the first large coal, in the recess of the front coal between the flame baffle and the front coal, Diagram 19.

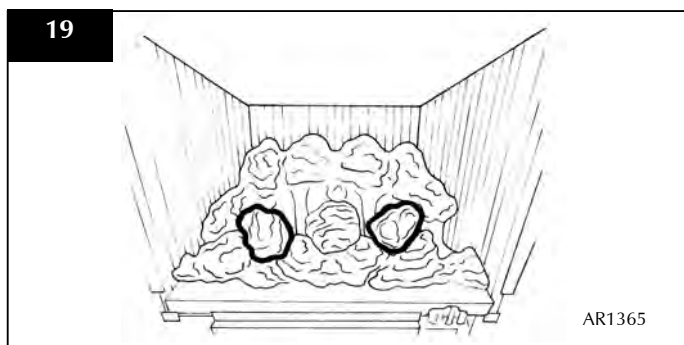

- Place another two medium size coals behind the first three coals and against the flame baffle, Diagram 20.

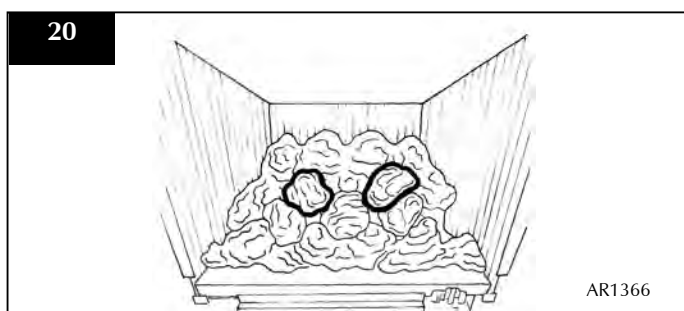

- Place a small coal directly behind the first large coal, and in between the centre of the last two medium coals resting on the flame baffle, Diagram 21

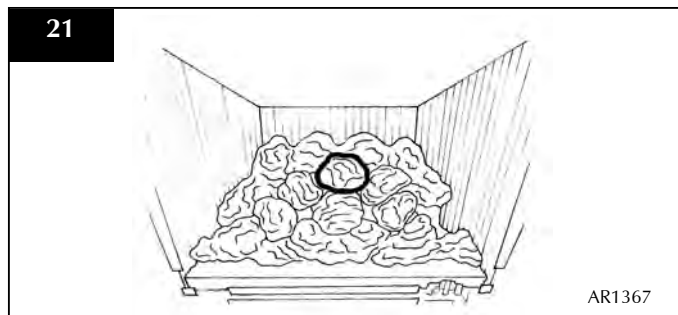

- Place the last two small coals to the left and right-hand side of the bed in the two spaces, Diagram 22

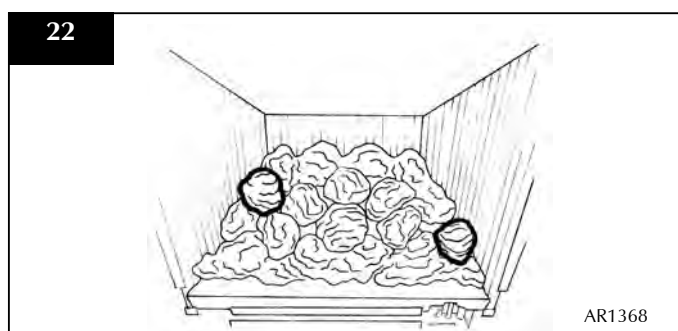

PEBBLE LAYOUT

- Position the pebble flame baffle centrally on the tray and ensure the stepped lower edge engages against the rear edge of the burner skin, Diagram 23

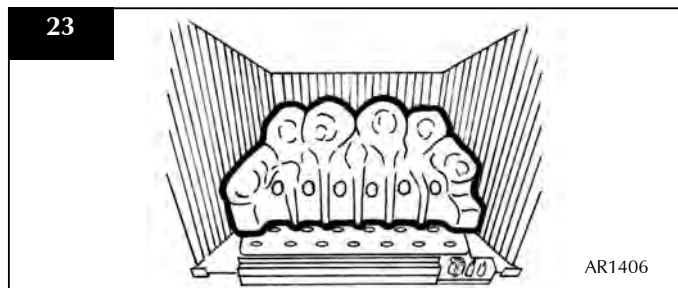

- Place the front pebble piece centrally in the channel at the front of the tray. See Diagram 24

INSTALLATION INSTRUCTIONS

INSTALLATION

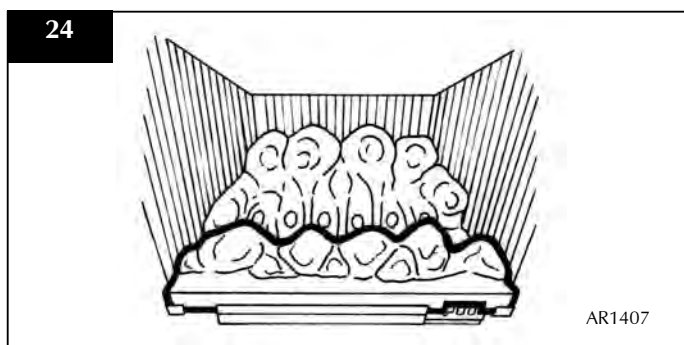

9.4 There are 10 loose pebbles in the set supplied. Each pebble is individually marked. The quantity of each type is shown below.

A1 x 3 A4 x 1
 A2 x 1 A5 x 1
 A3 x 3 A6 x 1

- Place the four pebbles as shown resting between the front ceramic and the flame baffle, Diagram 25

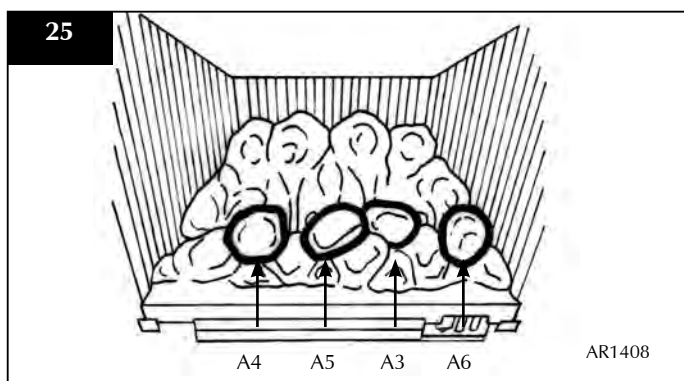

- Place the next four pebbles as identified resting between the flame baffle and the first row of pebbles as shown in Diagram 26

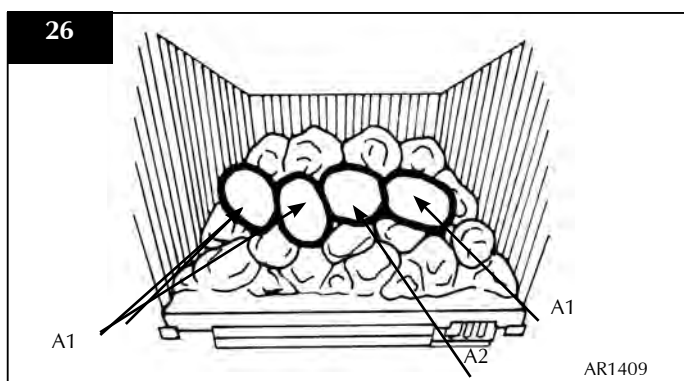

- Place the remaining two A3 pebbles as shown in Diagram 27.

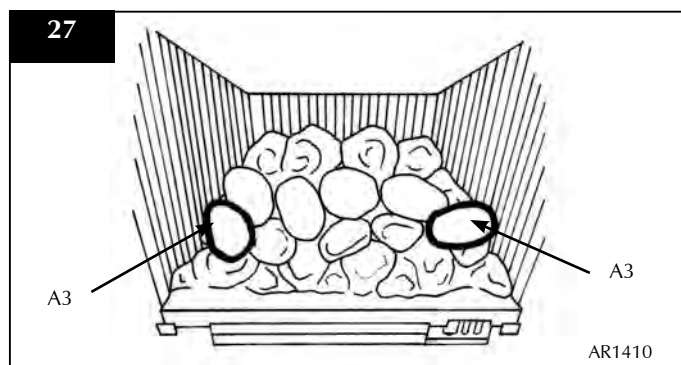

9.5 The coals/pebbles should evenly cover the whole bed with the gaps between them kept equal. This will maximise the performance of the product.

9.6 **ENSURE THAT THE COALS/PEBBLES ARE POSITIONED AS ABOVE. ONLY USE THE CORRECT AMOUNT OF COALS/PEBBLES AS SPECIFIED IN THE DIAGRAMS.**

FITTING THE GLASS WINDOW - E-BOX

- 9.7
- Ensure that the fibre glass window seal on the box is intact, then lower the glass window into the lower retaining bracket.
 - Hold the window and position the upper retaining bracket
 - Secure using the 4 screws.
 - Tighten the bottom and top screws to retain the window, Diagram 28.

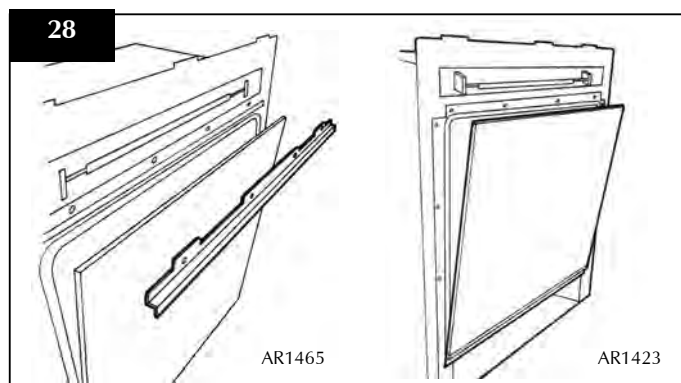

- Refer to the separate *Frame Instructions* to replace the frame on the fire

NEVER OPERATE THE APPLIANCE WHEN THE GLASS PANEL IS REMOVED OR BROKEN.

INSTALLATION INSTRUCTIONS

INSTALLATION / COMMISSIONING

10. LIGHTING THE APPLIANCE

- 10.1 • Locate the control valve on the fire. There are two control knobs on the valve, the right-hand knob controls the pilot ignition and the left hand knob controls the main burner.
- 10.2 If your fire has already been upgraded to battery remote control, please refer to the instructions provided with the upgrade to operate the remote control. The following instructions will work for either situation.

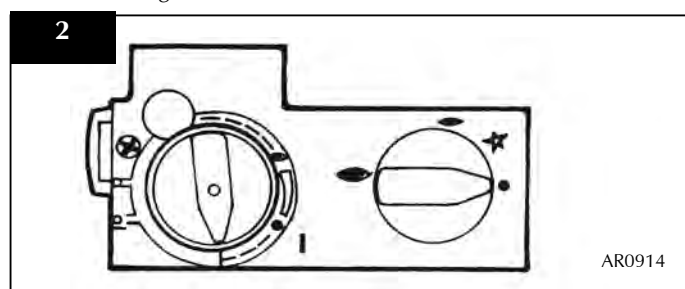

- Ensure that the left-hand control knob is pointing to off (●).
- Ensure that the right hand control knob is pointing to off (●).
- Press in the right hand control knob and rotate it anti-clockwise until a click is heard (keep pressing in) and the knob is pointing to pilot (☞). The pilot should now light. If the pilot has not lit, repeat the procedure until it does.
- Keep the control knob pressed for 10 seconds and then release it, the pilot should stay alight. If the pilot goes out, repeat the procedures until it does.
- Turn the right-hand control to point to main burner (☞). The fire can now be controlled using the left-hand control knob.
- Turn the left hand control knob to point to low fire (☞), the main burner will light on low. The burner can now be controlled between low and high settings. Turn the control knob anticlockwise increase the flame height and clockwise to decrease the flame height.

THE YELLOW FLAMES WILL APPEAR WHEN THE FIRE HAS GAINED SUFFICIENT HEAT - TYPICALLY 10 TO 20 MINUTES.

11. COMMISSIONING

- 11.1 Check all ceramics, doors etc.
- 11.2 Check flame picture
- 11.3 Check gas pressure

SERVICING INSTRUCTIONS

SERVICING / FAULT FINDING CHARTS

1. SERVICING REQUIREMENTS

This appliance must be serviced at least once a year by a competent person.

All tests must be serviced by best practice as described by the current CORGI recommendations.

- 1.1 Before any tests are undertaken on the appliance, conduct a gas soundness test for the property to ensure that there are no gas leaks prior to starting work.
- 1.2 Before any tests are undertaken on the appliance it is also recommended to fully check the operation of the appliance.
- 1.3 Special checks
 - 1.3.1 Check the flue terminal position complies with the requirements, and that the terminal is not obstructed.
 - 1.3.2 Clean away any debris under the burner.
 - 1.3.3 Check the condition of ceramics, pilot and burner cover gasket.
- 1.4 Correct any faults found during the initial tests and then re-commission the appliance conducting the usual safety checks.
- 1.5 Advise the customer of any remedial action taken.

IGNITION FUNCTIONAL CHECK 1

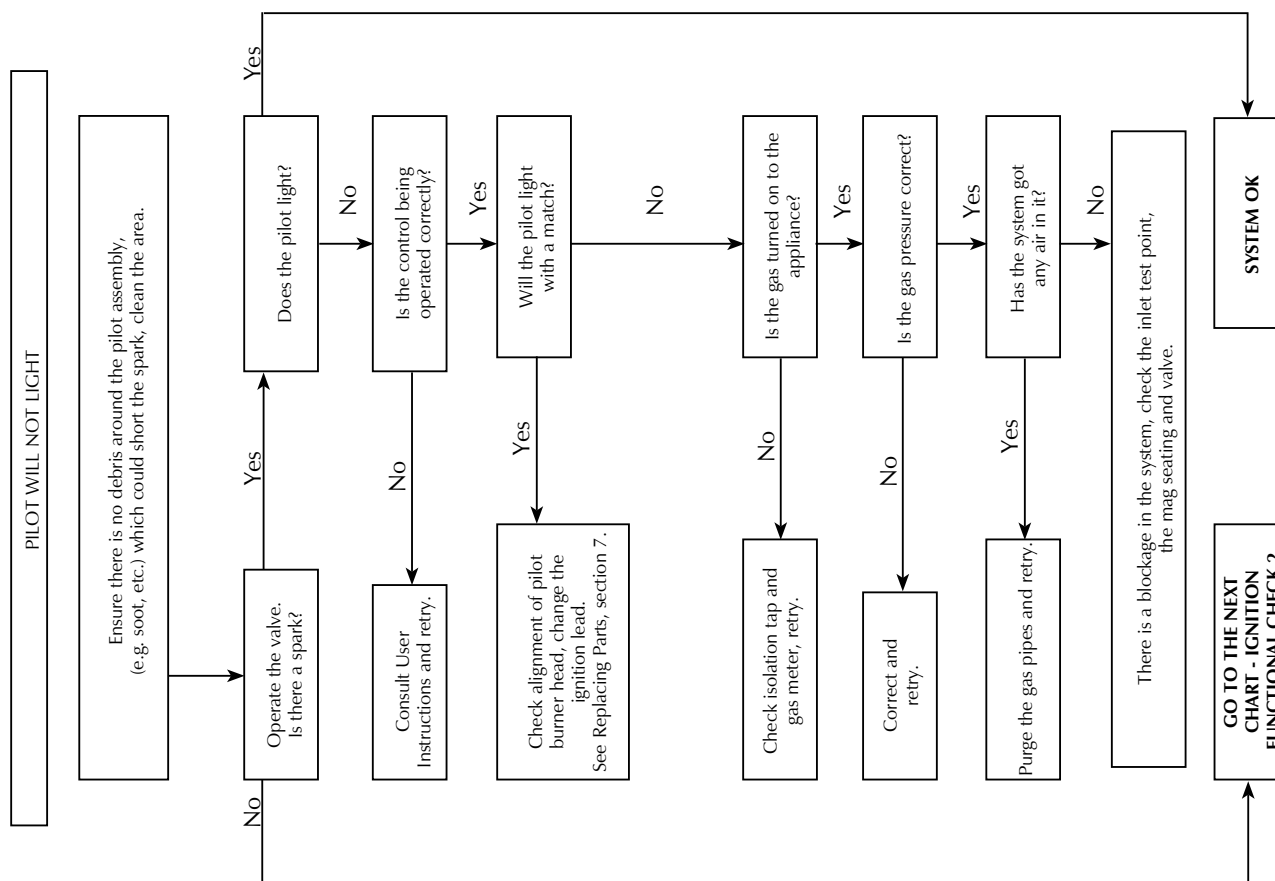

SERVICING INSTRUCTIONS

FAULT FINDING CHARTS

FLAME FAILURE FUNCTIONAL CHECK 3

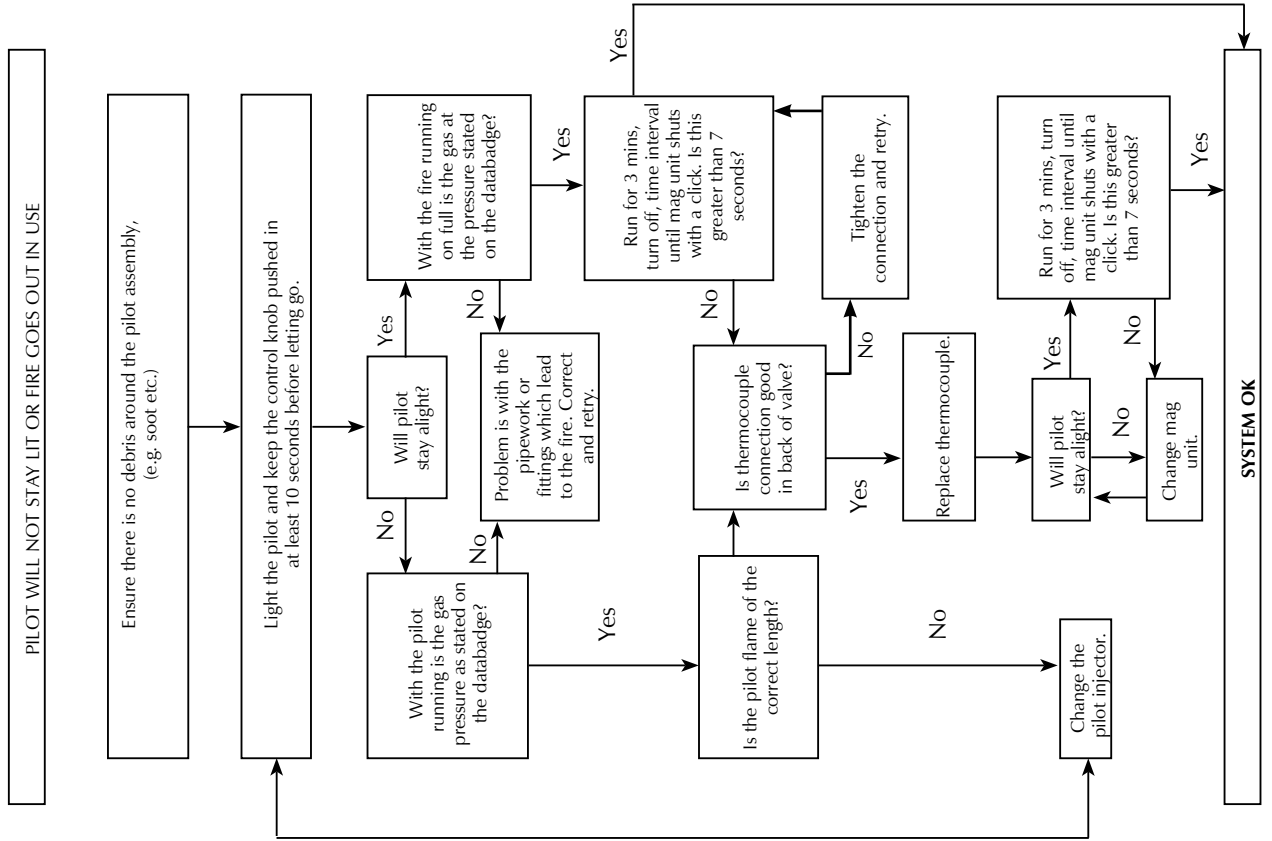

IGNITION FUNCTIONAL CHECK 2

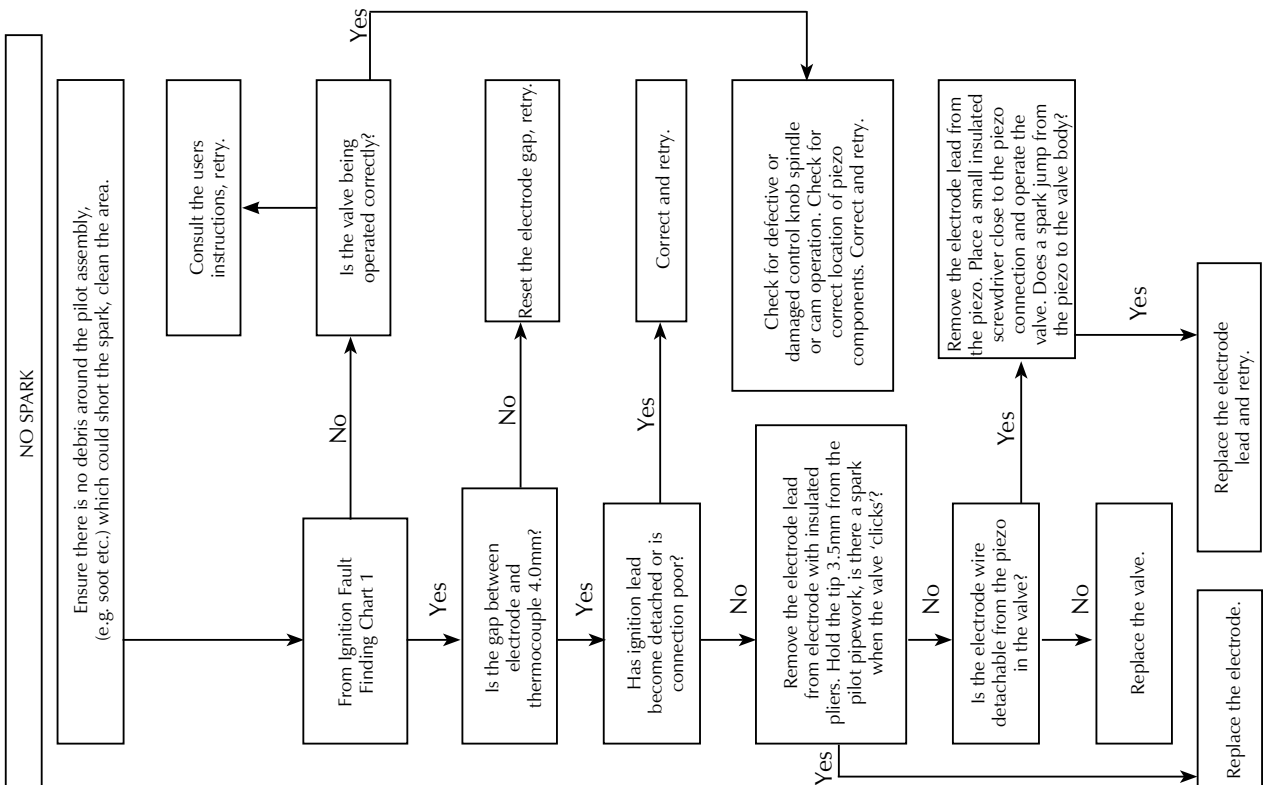

SERVICING INSTRUCTIONS

REPLACING PARTS

1. GENERAL

- 1.1 All principal components can be replaced without removing the appliance from its installation, although it is essential that the gas supply to the appliance is turned off at the isolation device before proceeding further.
- 1.2 Before replacing some of the components it will first be necessary to remove the burner assembly from the appliance by following the instructions below.
- 1.3 If for any reason the flue has to be removed from the appliance, the seal must be replaced in the inner spigot.

2. REMOVING THE BURNER UNIT

Ensure the appliance is cold before proceeding

- 2.1
 - Turn the gas supply off at the isolation device. Then disconnect the supply pipe.
 - Remove the frame from the appliance by referring to the separate frame instructions supplied.

2A. E-STUDIO

- Remove the one-piece glass window frame by removing the eight fixing screws, Diagram 1

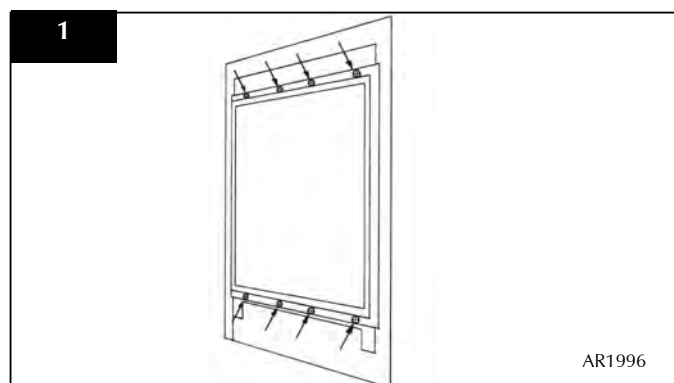

- Remove the granite chippings from the appliance.
- Remove the top inner baffle by unscrewing the two fixing screws located on the front edge of the top plate, Diagram 2

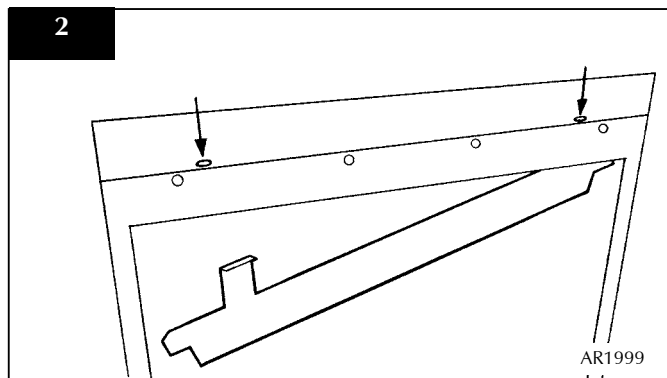

- Carefully remove the enamel back panel by rotating it out of the fire box, Diagram 3

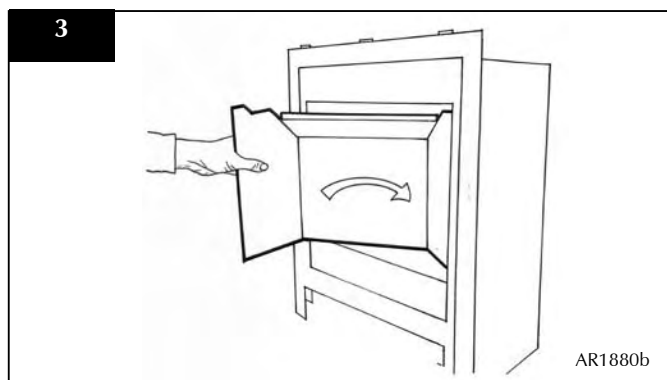

TAKE EXTREME CARE WHILST REMOVING THESE PANELS NOT TO SCRATCH OR CHIP THE PANEL ON THE SIDES OF THE FIREBOX

- Unscrew the 3 fixings in the rear liner support, Diagram 4, and lift this part out of the appliance.

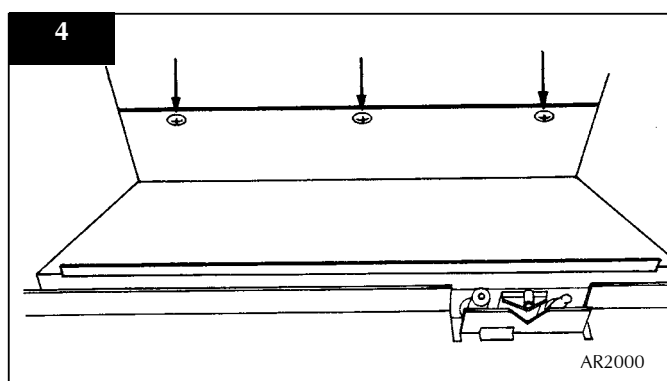

- Remove the left and right-hand burner baffle brackets by unscrewing the two fixings located on the burner tray top, Diagram 5

SERVICING INSTRUCTIONS

REPLACING PARTS

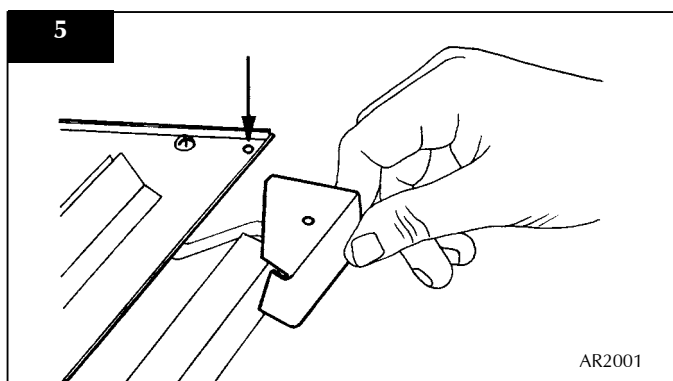

- Remove the 11 screws that fix the burner assembly into the appliance, Diagram 6. The burner assembly can now be removed by lifting it up and out of the appliance.

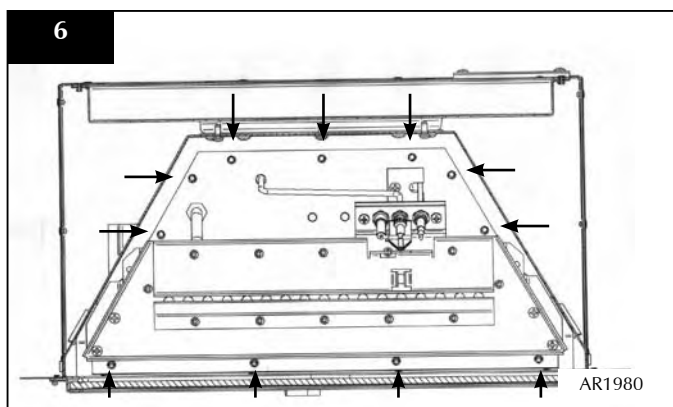

2B. E-BOX

- Remove the glass window by loosening the four screws in the lower retaining bracket then remove the four top screws and retaining bracket. The glass window can now be lifted clear, Diagram 7

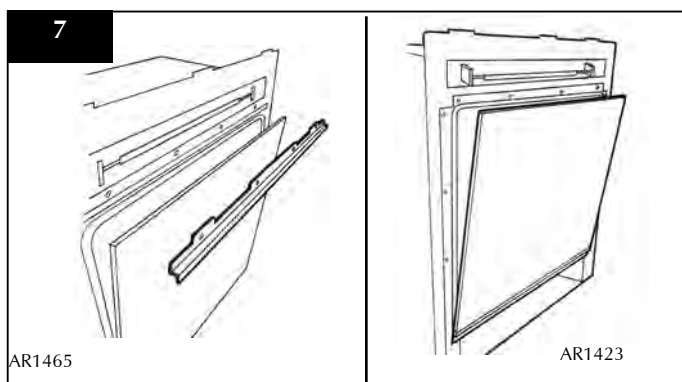

- Remove the ceramic coals and fuel bed and place on a dry clean surface
- Remove the ceramic panels from inside the appliance
- Remove the two screws securing the front U channel on the burner assembly. This is to gain access to the burner retaining screws, Diagram 8.

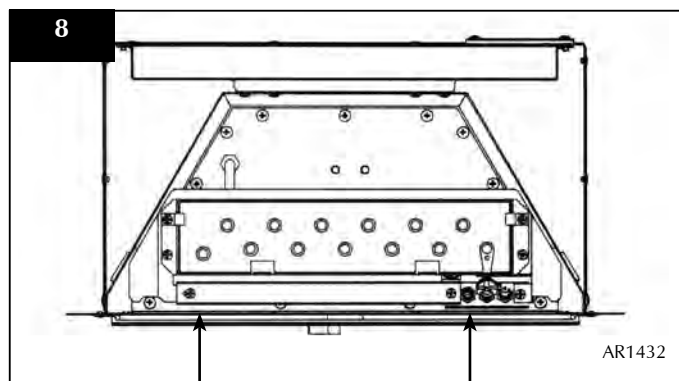

- 2.14
- Remove the 11 screws in the burner tray securing the burner assembly to the appliance. The burner assembly can now be removed by lifting it up and out of the appliance, Diagram 9.

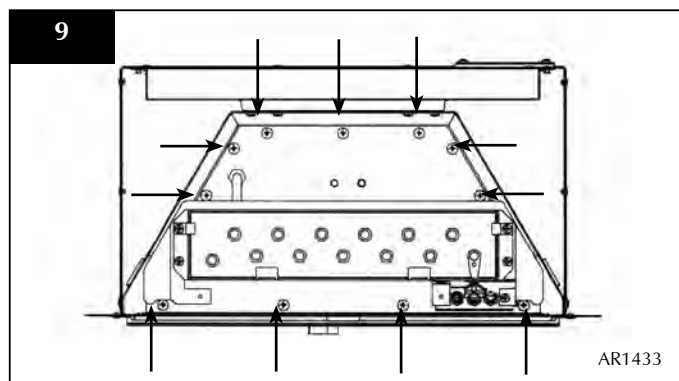

3. PILOT UNIT

The pilot unit assembly consists of three components which can be individually changed, these are:-

- 1) Pilot Injector
- 2) Electrode
- 3) Thermocouple

Note: On the E-Box, access is provided for the removal of the pilot without removing the engine assembly. It is easier, however, to change the pilot by removing the whole assembly.

SERVICING INSTRUCTIONS

REPLACING PARTS

4A. PILOT INJECTOR - E-STUDIO

- 4.1
- Undo the pilot pipe from the bulkhead fitting and from the underside of the pilot unit, Diagram 10

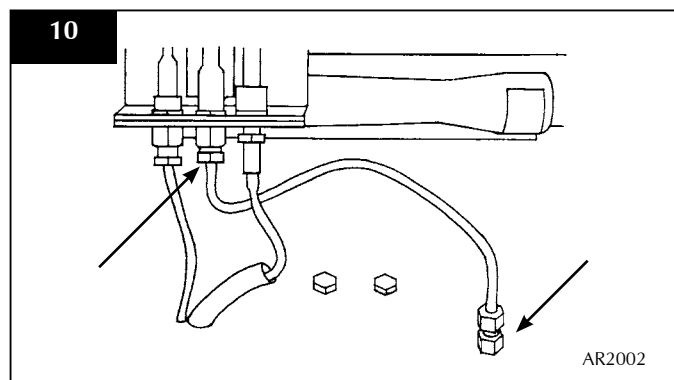

- Remove the pipe and the injector drops out from the pilot unit. Take care not to loose or damage the injector.

- 4.2 To replace the injector:

- Reverse the above procedure
- Check for gas leaks.

4B. PILOT INJECTOR - E-BOX

- 4.3
- Undo the pilot pipe from the valve and from the under side of the pilot unit, Diagram 11

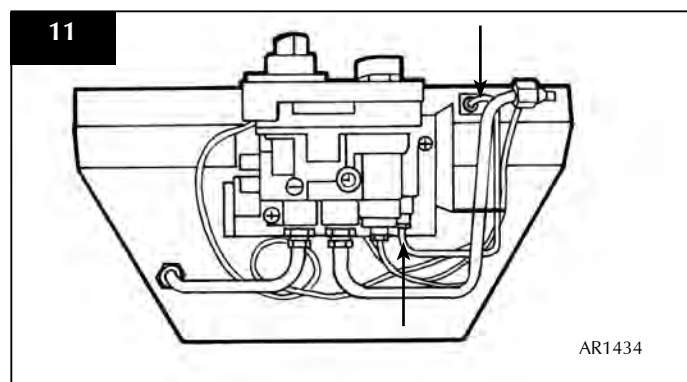

- Remove the pipe and the injector drops out from the pilot unit. Take care not to loose or damage the injector.

- 4.4 To replace the injector:

- Reverse the above procedure
- Check for gas leaks

5. ELECTRODE

- 5.1
- Pull the ignition lead from the electrode and undo the retaining nut, Diagram 12

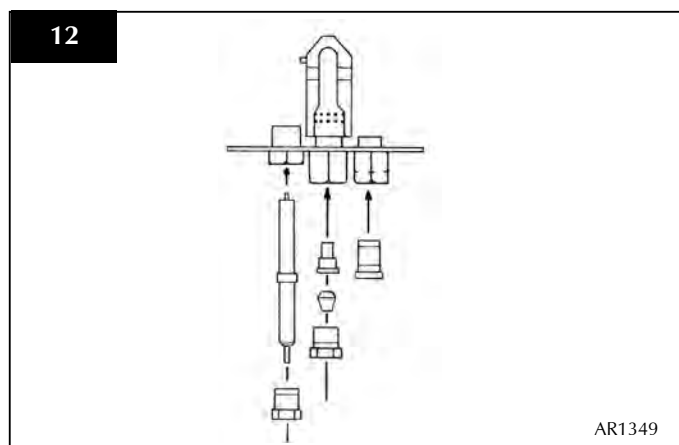

- Replace with new electrode. Do not over tighten the nut as this could break the new component
- Replace the ignition lead

6. THERMOCOUPLE

- 6.1
- Disconnect the thermocouple from the gas valve, Diagram 13

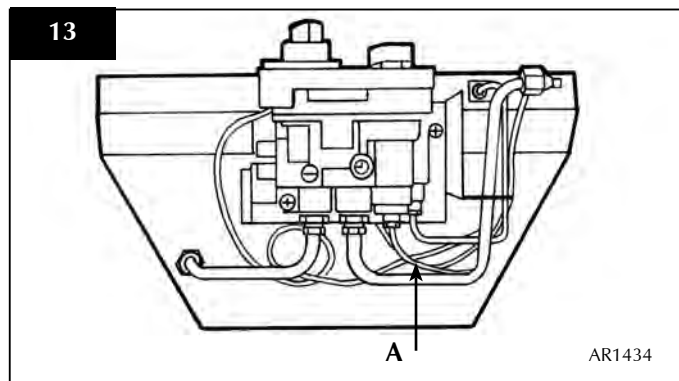

- Undo the thermocouple nut in the pilot unit by half a turn. This will release the thermocouple.

For E-Studio

- 6.2
- Remove the sealing plate, Diagram 14, by removing the pozi head screw.

NOTE: The sealing plate needs to be re-sealed after the new thermocouple is fitted.

SERVICING INSTRUCTIONS

REPLACING PARTS

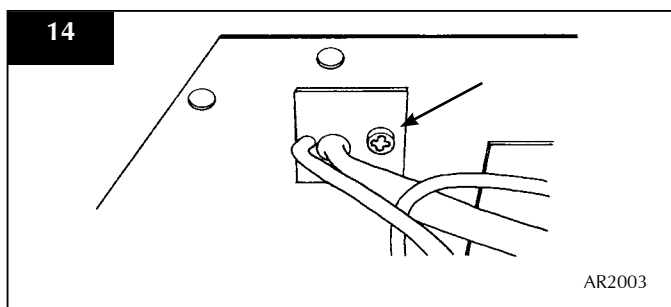

WHEN REPLACING WITH A NEW THERMOCOUPLE TAKE CARE TO BEND THE NEW COMPONENT TO THE EXACT SHAPE OF THE ORIGINAL ONE

- 6.3 When replacing the thermocouple into the pilot unit ensure the component is pushed fully into the hole. There is a stop on the thermocouple to set the height.
- Lock the retaining nut just enough to grip the thermocouple

7. IGNITION LEAD

- 7.1
- Remove the burner unit. Refer to section 2
 - Undo the single screw that secures the left hand side of the control cover, Diagram 15.

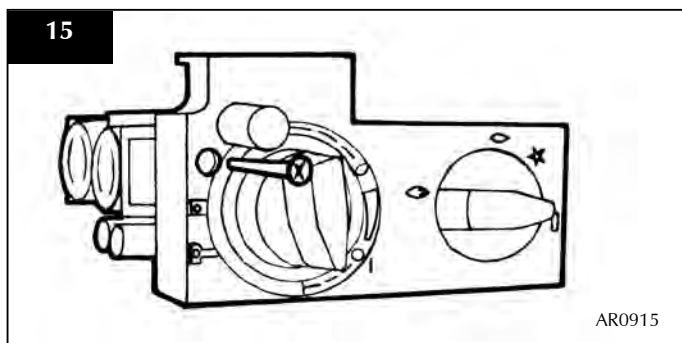

- 7.2 To release the right hand side of the control cover:
- Insert the narrow blade screwdriver into the slot shown in Diagram 16
 - Lever it gently and pull from the right hand side at the same time. The cover will now come off, there is a small cylindrical metal spacer inside the cover. This must be kept and replaced on the fixing screw during re-assembly.

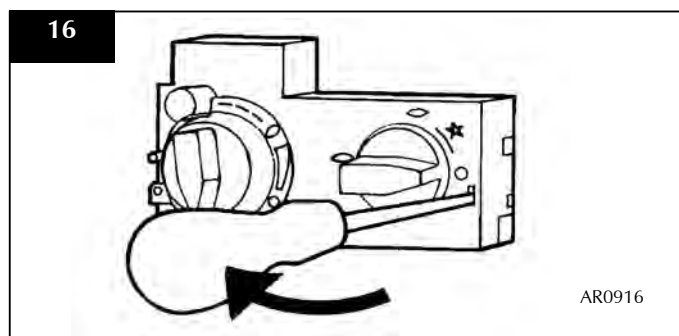

- Disconnect the ignition lead from the valve and electrode.

(For E-Studio, the sealing plate needs also to be removed, Diagram 14)

- Replace with a new ignition lead following the same route as the old one.

(For E-Studio, replace the sealing plate and re-seal with relevant sealant).

- Replace the valve cover check the operation of the new ignition lead.

- 7.3
- Refit the burner unit
- 7.4
- Replace the fire frame

8. PIEZO

- 8.1 The piezo assembly used on this appliance is not serviceable and is unlikely to fail. If a new piezo is required it will be necessary to change the gas valve, refer to section 9.

9. GAS VALVE

- 9.1
- Remove the thermocouple from the valve, Diagram 17, Arrow A.
 - Undo the pilot pipe from the gas valve, Diagram 17, Arrow B.
 - Undo the inlet pipe from the valve, Diagram 17, Arrow C.
 - Undo the feed pipe from the valve, Diagram 17, Arrow D.
 - Disconnect the ignition lead from the pilot unit. (For E-Studio, the sealing plate needs to be removed, Diagram 14)

SERVICING INSTRUCTIONS

REPLACING PARTS

- Undo the two screws securing the valve to the bracket, Diagram 17, Arrow E. The valve can now be removed.

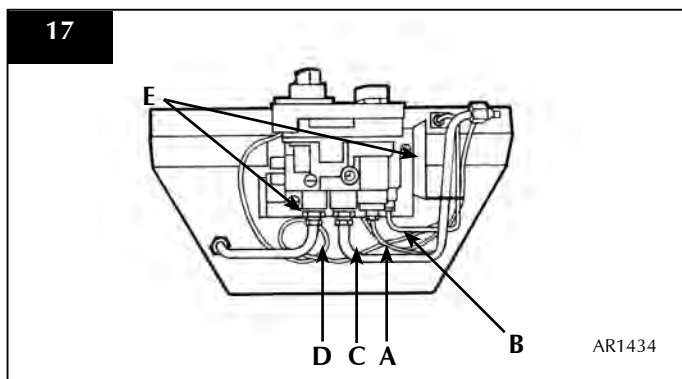

10. MAG UNIT

- 10.1 Undo the thermocouple nut, Diagram 18, Arrow A.

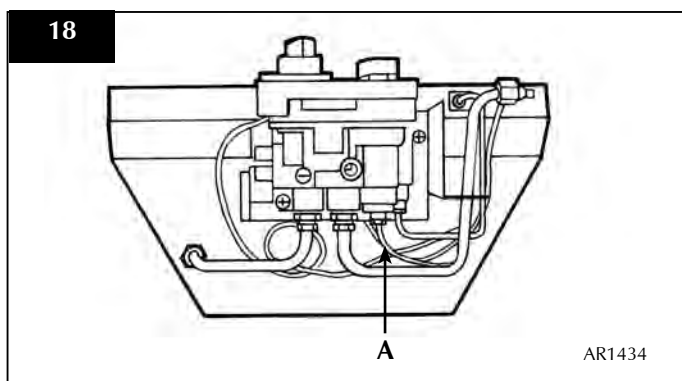

- Undo the mag unit retaining nut at the back of the control valve behind the thermocouple nut

After removing the retaining nut, the mag unit can be tapped out and a replacement fitted.

- Replace the mag unit retaining nut and tighten. Note - this is a gas-tight seal
- Replace the thermocouple and check for gas leaks

- 10.2 After reassembly, carry out the flame failure functional check as detailed in the flow chart, especially the mag unit drop out time.

11. MAIN INJECTOR

- 11.1 • Undo the two nuts securing the injector pipe, Diagram 19

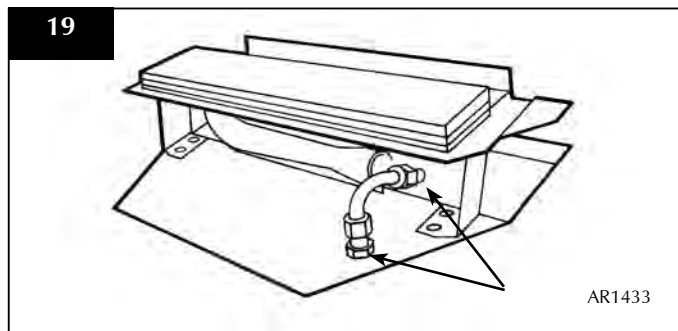

- Rotate the injector until it is fully removed
- Replace with the correct replacement injector. When ordering, always state the model, gas type and serial number.
- Reassemble and turn the gas supply on, check for any leaks

12. CHANGING BETWEEN GAS TYPES

The following parts must be changed when converting an appliance from one gas type to another:

	E-BOX		E-STUDIO	
BURNER ASSEMBLY	NG	A8692	NG	GZ6398
	LPG	AP8692	LPG	GZ6960
DATABADGE	PR0393EBF			

Note: The control valve will be set for the particular appliance and gas type. In all instances, when ordering new parts, be sure to quote the appliance type and serial number.

Use only genuine Gazco replacement parts. Non-standard components will invalidate the guarantee and may be dangerous.

SERVICING INSTRUCTIONS

REPLACING PARTS

13A. SPARE PARTS LIST - E-STUDIO

PART DESCRIPTION	PART NUMBER
Stone chippings	CE0647
Vitreous Enamel Liner	GZ6847
NATURAL GAS PARTS	
Main Burner Injector	IN0060
Pilot Assembly	PI0069
Aeration Plate	GZ3966
LPG PARTS	
Main Burner Injector	IN0066
Pilo Assembly	PI0070
MISCELLANEOUS PARTS	
Gas Valve	GC0088
Ignition Lead	GC0090
Magnetic Unit	GC0092
Control Cover	GC0087
Upgrade Kit - standard	8455
Upgrade Kit - Thermostatic	8456
Window Seal	FA0461
Thermocouple	PI0074
Burner Tray Gasket	CE0513

13B. SPARE PARTS LIST - E-BOX

CERAMIC PARTS	COAL	PEBBLE
Front Coal / Pebble	CE0490	CE0502
Flame Baffle	CE0491	CE0503
Side Panel LH	CE0518	CE0562
Side Panel RH	CE0519	CE0563
Rear Panel	CE0497	CE0517
Top Panel	CE0523	CE0552
Coal Set / Peble Set	CE0496	CE0504
NATURAL GAS PARTS		
Main Injector	IN0001	
Pilot Assembly	PI0069	
Aeration Plate (NG)	GZ3867	
LPG PARTS		
Main Injector	IN0056	
Pilot Assembly	PI0070	
Aeration Plate (LPG)	GZ2016	
MISCELLANEOUS		
Gas Valve	GC0088	
Ignition lead	GC0090	
Magnetic Unit	GC0092	
Control Cover	GC0087	
Upgrade Kit Standard	8455	
Upgrade Kit Thermostatic	8456	
Window Seal	FA0461	
Burner cover Gasket	CE0528	
Burner Tray Gasket	CE0513	

SERVICE RECORDS

1ST SERVICE

Date of Service:.....

Next Service Due:.....

Signed:.....

Dealer's Stamp/CORGI Registration Number

2ND SERVICE

Date of Service:.....

Next Service Due:.....

Signed:.....

Dealer's Stamp/CORGI Registration Number

3RD SERVICE

Date of Service:.....

Next Service Due:.....

Signed:.....

Dealer's Stamp/CORGI Registration Number

4TH SERVICE

Date of Service:.....

Next Service Due:.....

Signed:.....

Dealer's Stamp/CORGI Registration Number

5TH SERVICE

Date of Service:.....

Next Service Due:.....

Signed:.....

Dealer's Stamp/CORGI Registration Number

6TH SERVICE

Date of Service:.....

Next Service Due:.....

Signed:.....

Dealer's Stamp/CORGI Registration Number

7TH SERVICE

Date of Service:.....

Next Service Due:.....

Signed:.....

Dealer's Stamp/CORGI Registration Number

8TH SERVICE

Date of Service:.....

Next Due:.....

Signed:.....

Dealer's Stamp/CORGI Registration Number

9TH SERVICE

Date of Service:.....

Next Due:.....

Signed:.....

Dealer's Stamp/CORGI Registration Number

10TH SERVICE

Date of Service:.....

Next Service Due:.....

Signed:.....

Dealer's Stamp/CORGI Registration Number

Gazco Limited, Osprey Road, Sowton Industrial Estate, Exeter, Devon, England EX2 7JG
Tel: Technical Customer Services (01392) 261950 Fax: (01392) 261951
E-mail: technicalservices@gazco.com

A member of the Stovax Group